

# ***Diabolo L***

***#4550***

































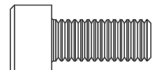





## ***Manual***

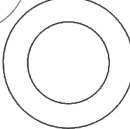





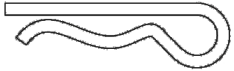















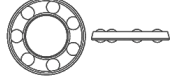



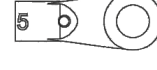









***minicopter  
Rheinstahling 47  
34246 Vellmar  
Germany  
Fon: +49 561 988 2800  
info@minicopter.de  
www.minicopter.de***

















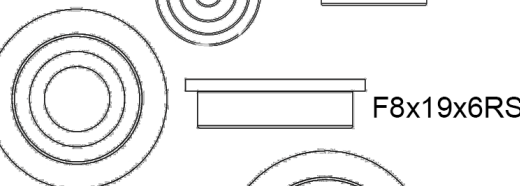
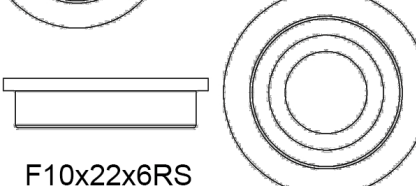
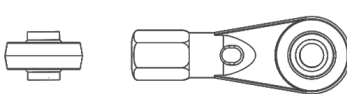

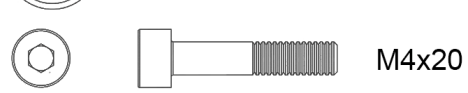
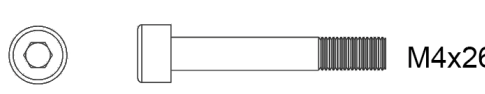

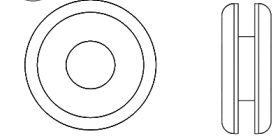
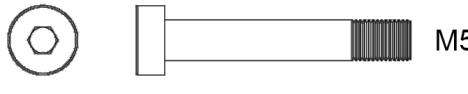
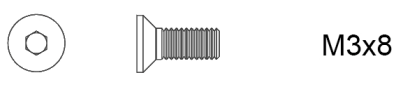



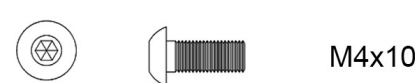

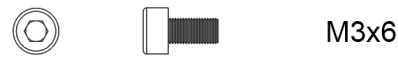
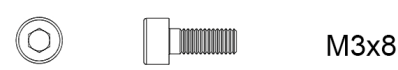

***minicopter***

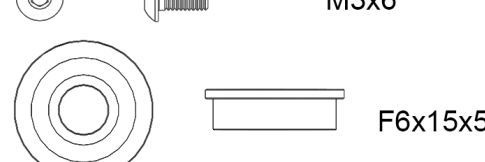
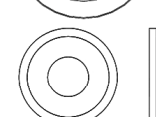
***Diabolo L***

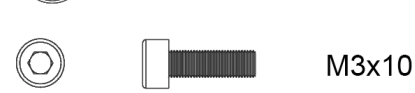
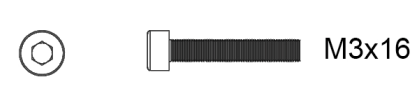
- 001   M2 5x2x0.2
- 002   M3 7x3x0.5
- 007   M2
- 008   M3
- 009   M4
- 010   M5
- 011   8x14x0.2
- 024   M3x8
- 025   M3x6
- 026   M3x10
- 033   10x16x0.2
- 034   M5x12
- 035   M4x5
- 041   2.5
- 045   6x12x0.1
- 047   8x14x0.5
- 048   10x16x0.1
- 051   3x6x1
- 054   7x10x0.2
- 060  
- 076  

- 078  
- 0087  
- 0092  
- 0099   M2x12
- 0112   5x9.8   5.2x10 
- 0316  
- 0385  
- 0492   M2.5x4
- 0494   M3x16
- 0507   M2.5x12
- 0573   M4x4
- 0593  
- 0942   5x10x4
- 0952   5x10x4
- 0980  
- 989   M3x10



D008		
D057		
D058		
D059		
D060		
D068		3x13x5
D070		F8x19x6RS
D071		F10x22x6RS
D072		
D074		
D077		M4x20
D078		M4x26
D079		
D080		
D090a		M5
D095		M3x8
D099		M3x6
D104		M3x18
D106		M4x8
D107		M4x10
D110		3x6x0.3
D116		
D118		4.8mm
D119		M3x12
D196		M3x6
D197		M3x8
D198		M3x14
D199		M3x6
D247		F6x15x5
D250		
D256		
D328		M3x10
D329		M3x16
D331		M3x20
D332		M3x22
D336		M3x25
D337		M3x30
D339		M3x40
D547		M3

1



D402



D401



D427



D401 & D402

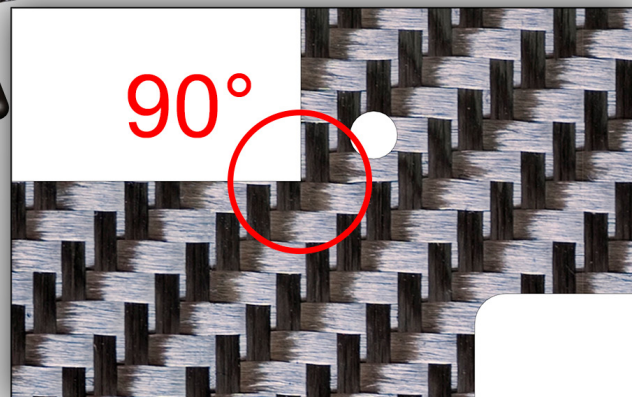
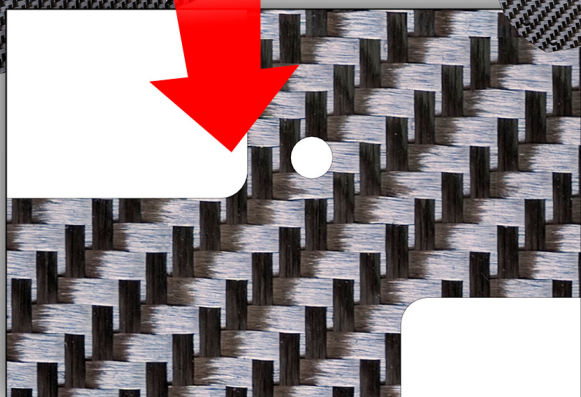
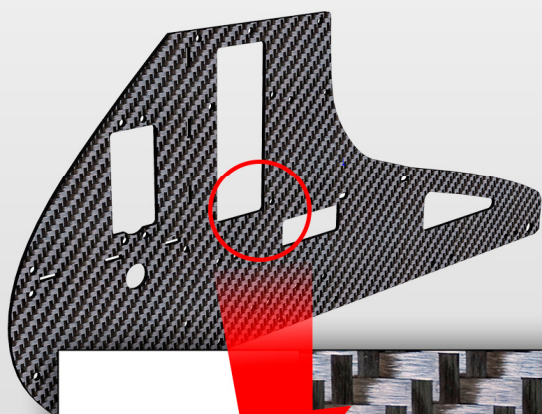

*minicopter*

*Diabolo L*





3



D12

D13

002 x 6

(L) D197 x 6

(L) = Loctite 243

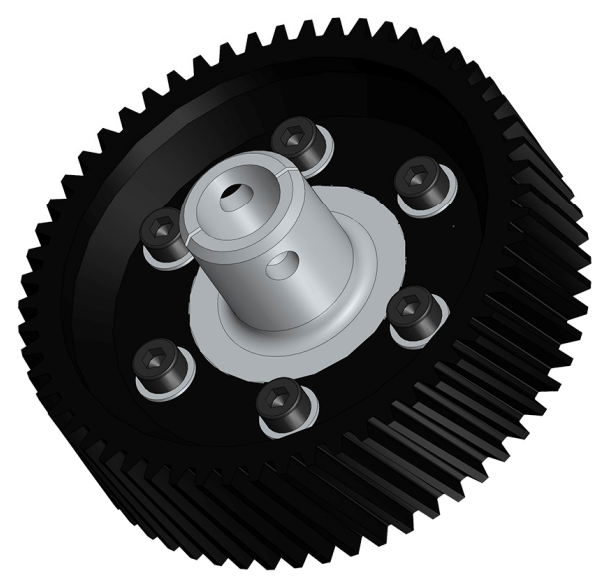
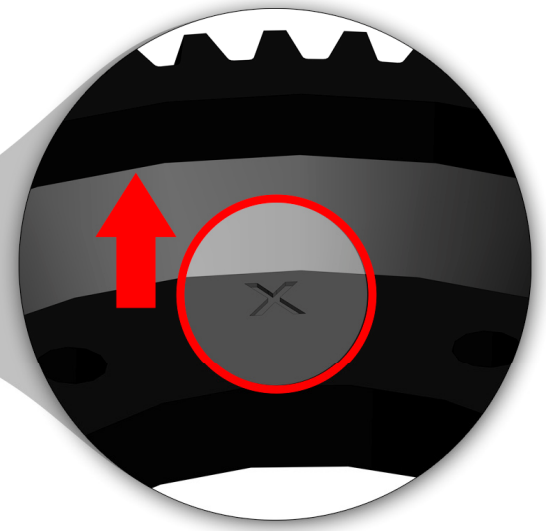

*minicopter*

*Diabolo L*



4

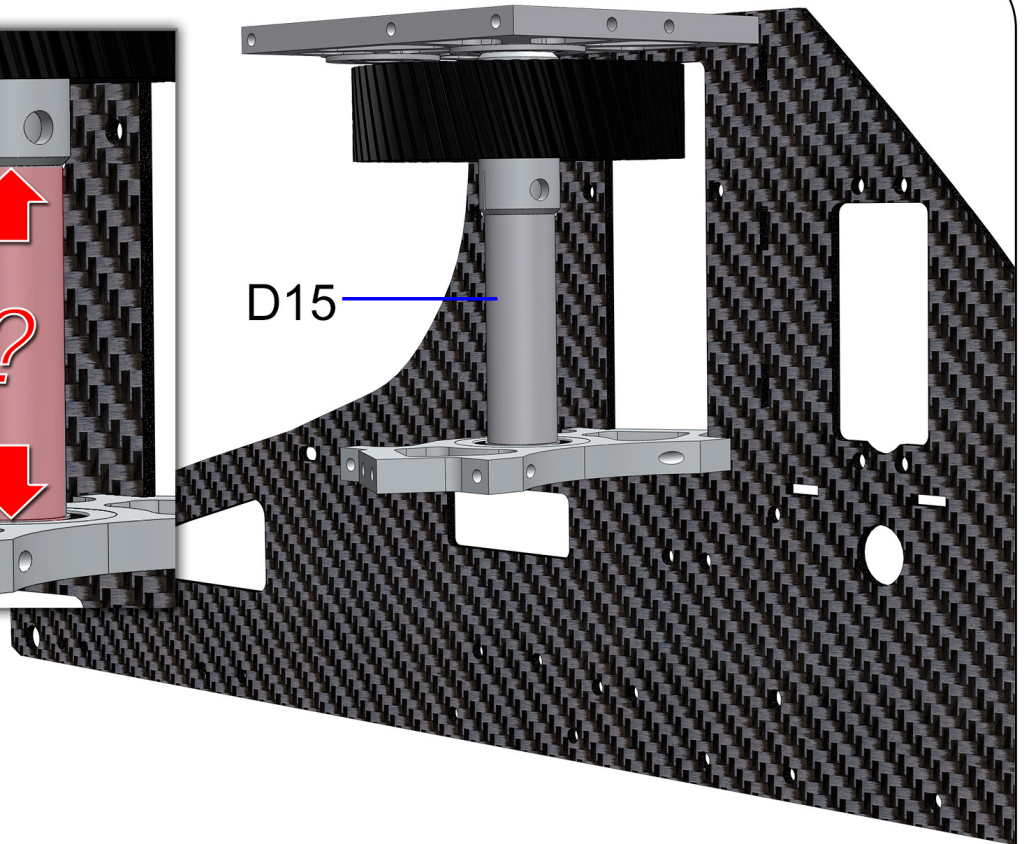
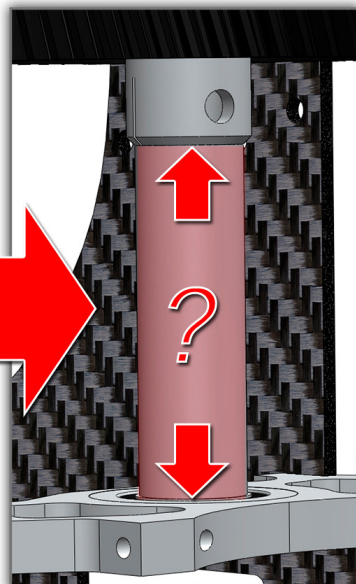
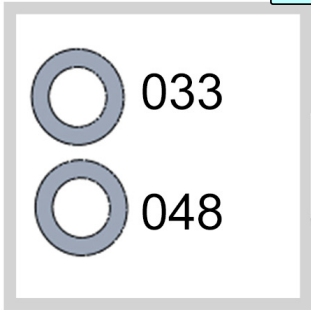

D15

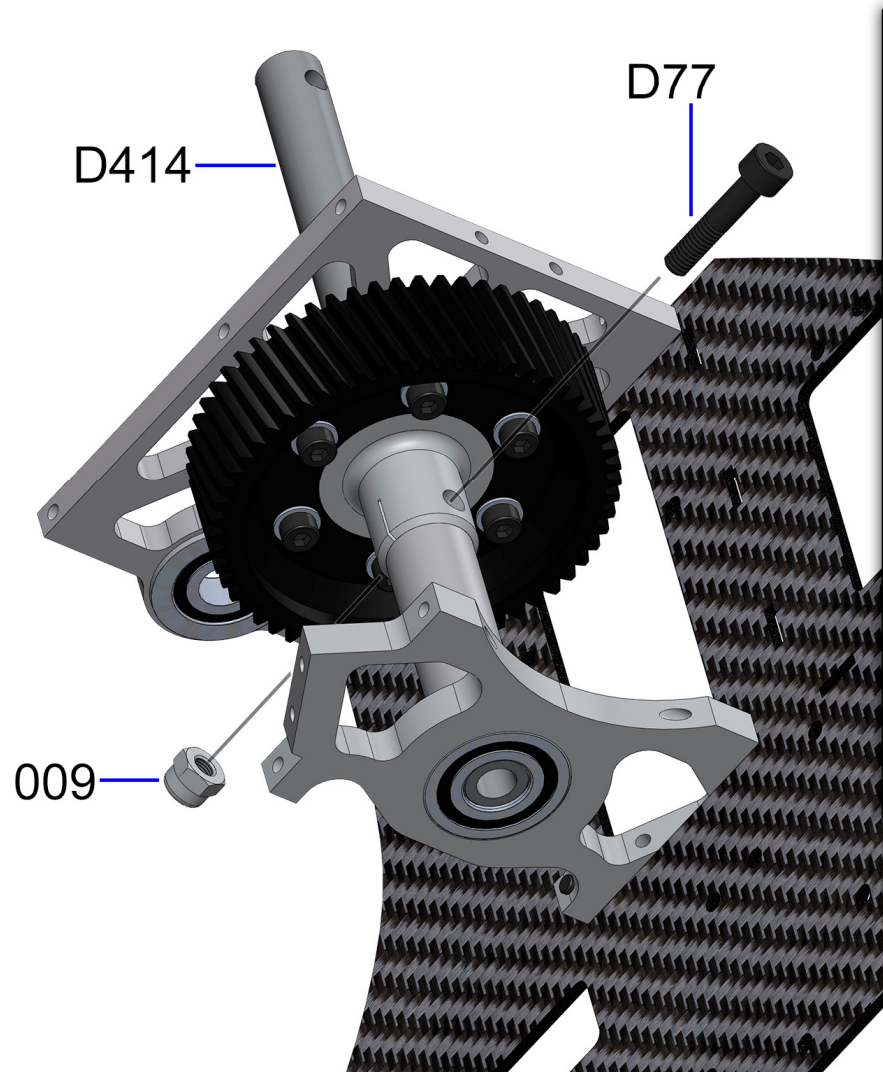

D414

D77

009

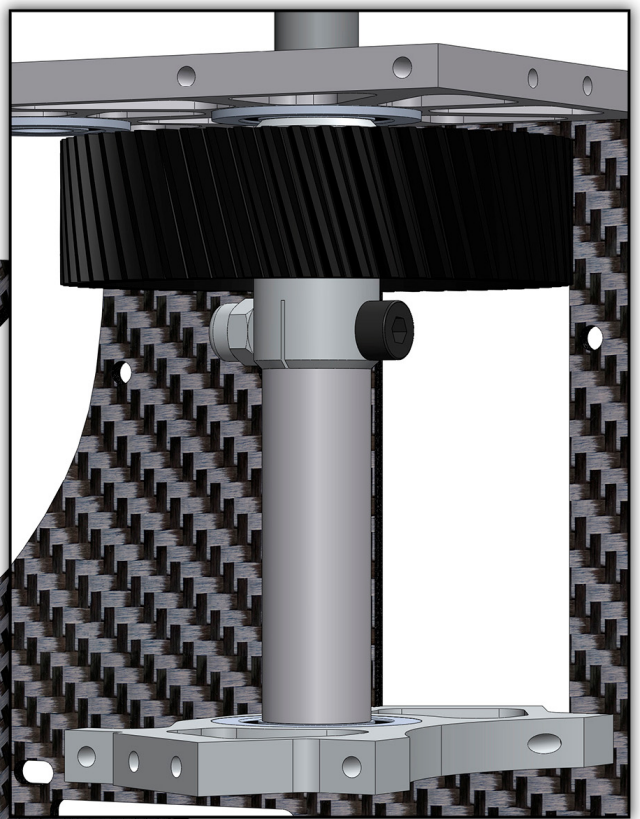

*minicopter*

*Diabolo L*

5

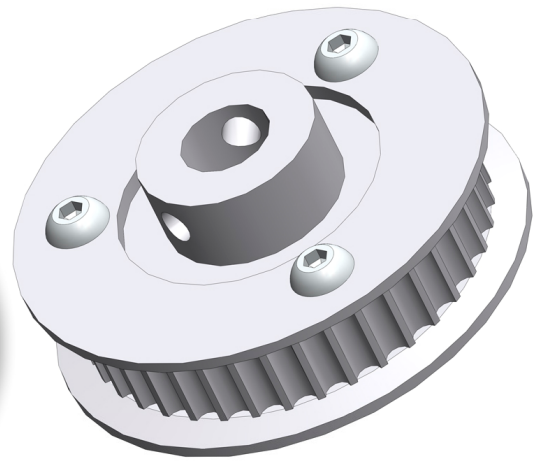
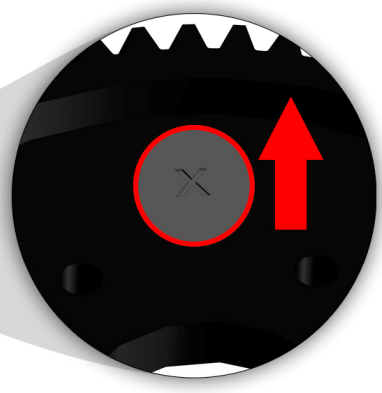
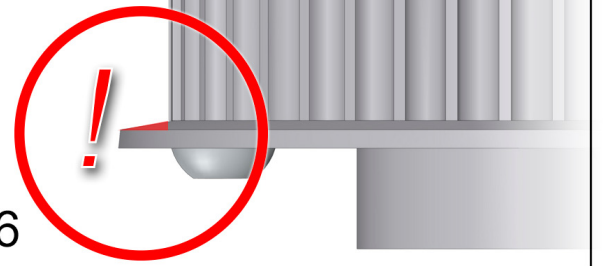
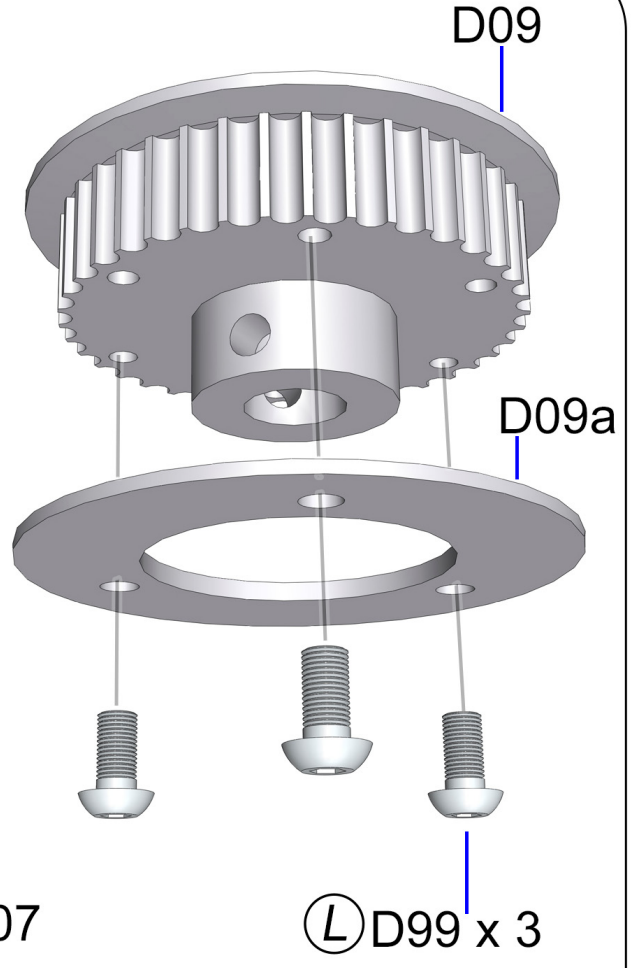
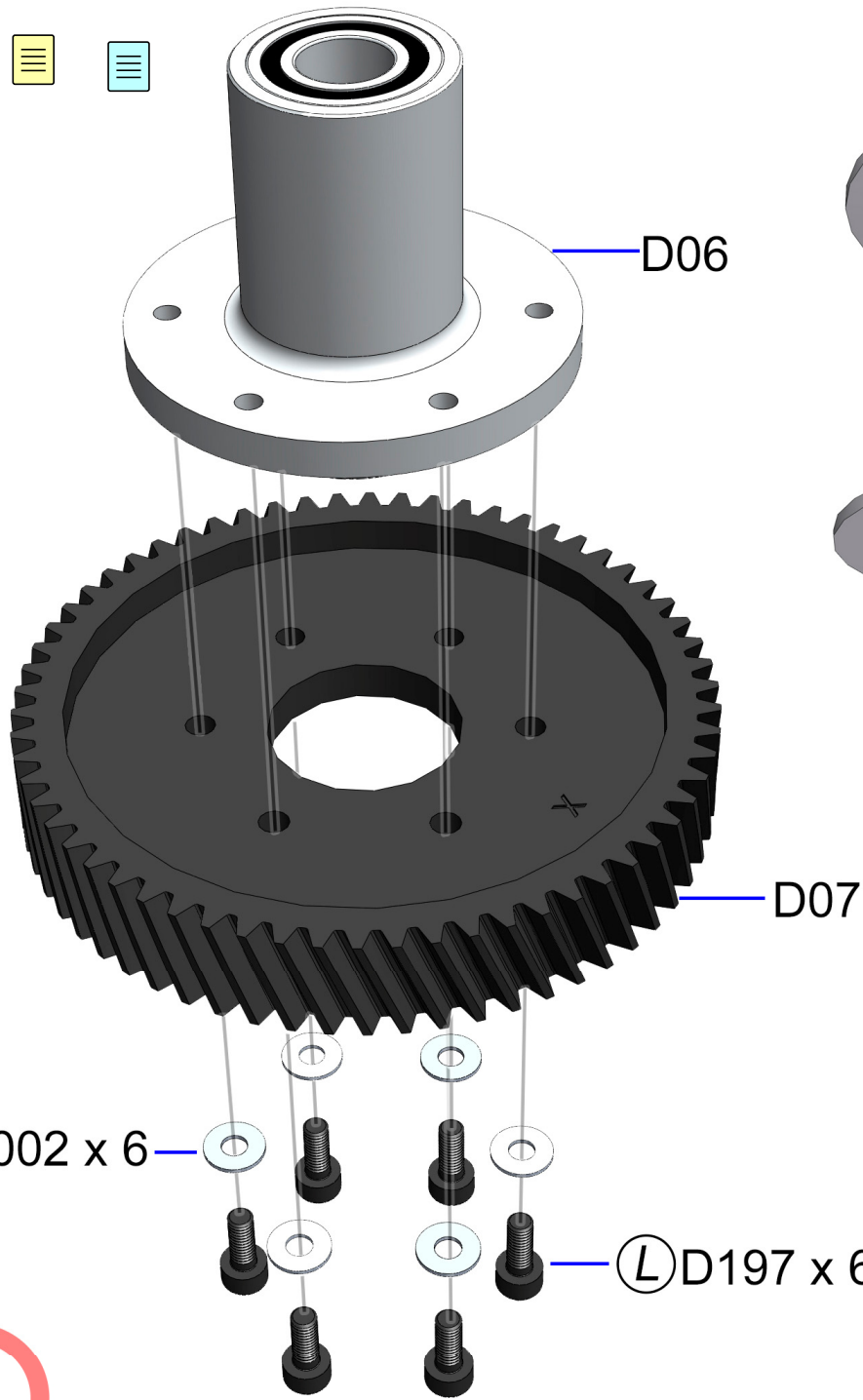

(L) = Loctite 243

*minicopter*

*Diabolo L*



6

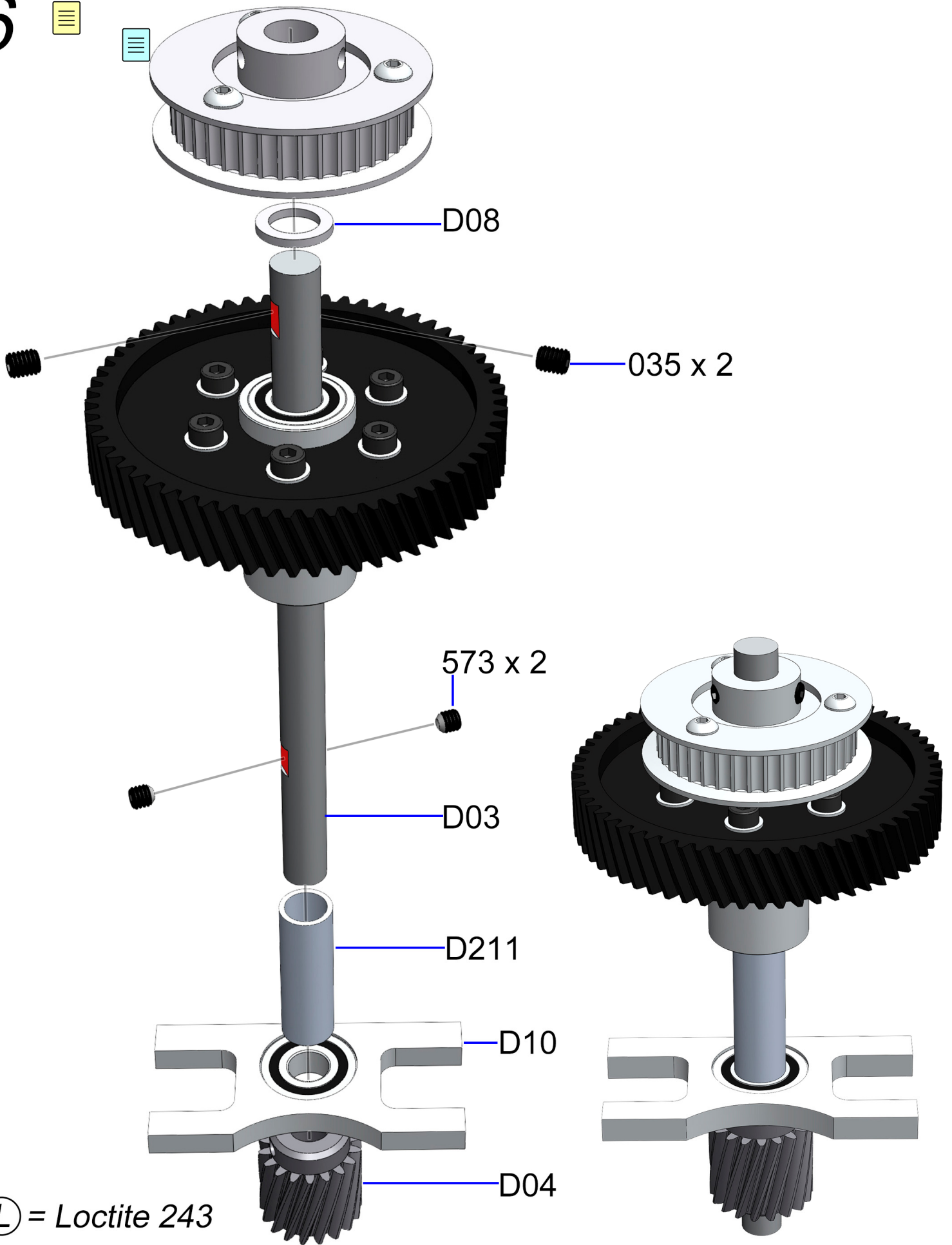

*minicopter*

*Diabolo L*

7

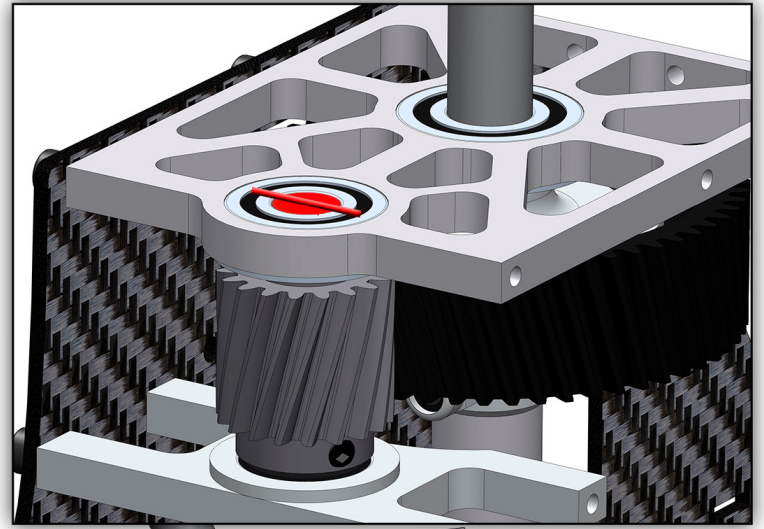
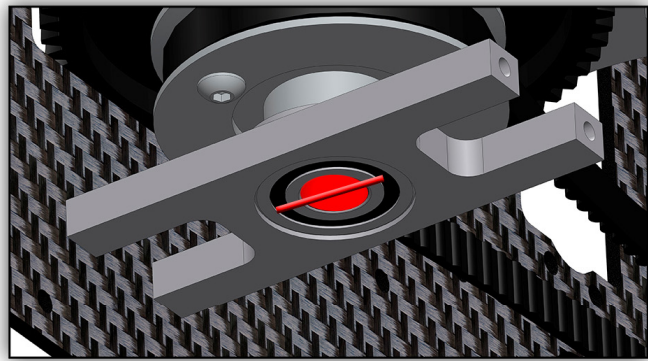
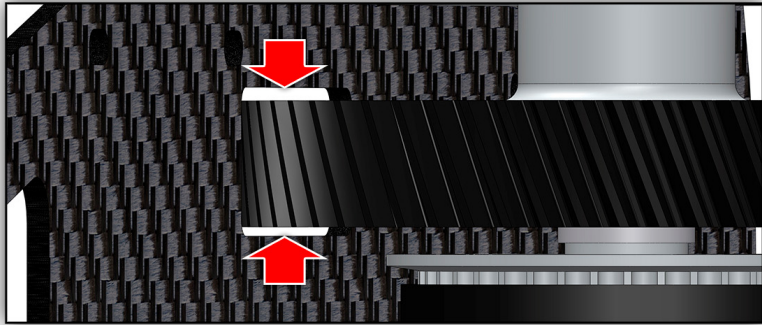

(L) D197 x 4

713

047

011

D070

(L) = Loctite 243

D11

*minicopter*

*Diabolo L*



8

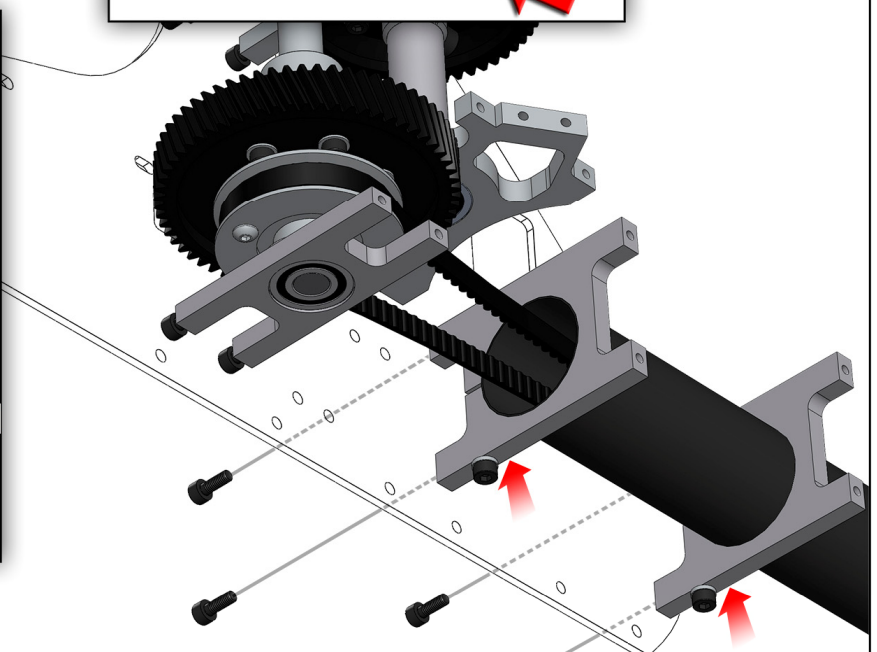
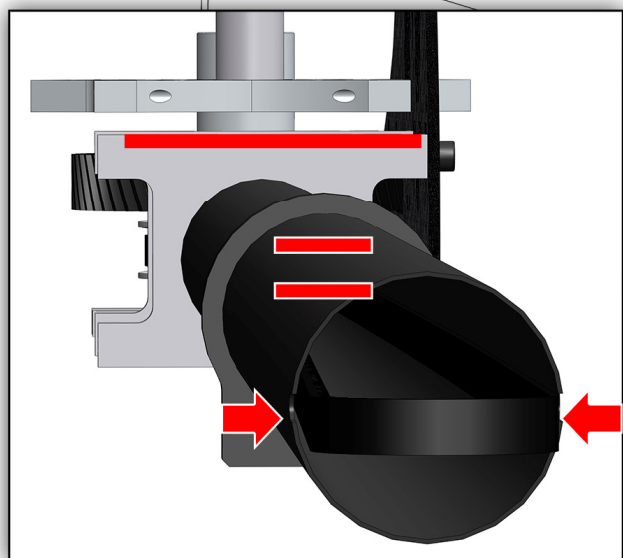
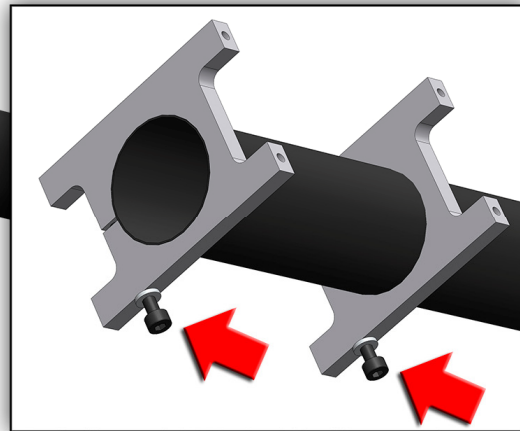
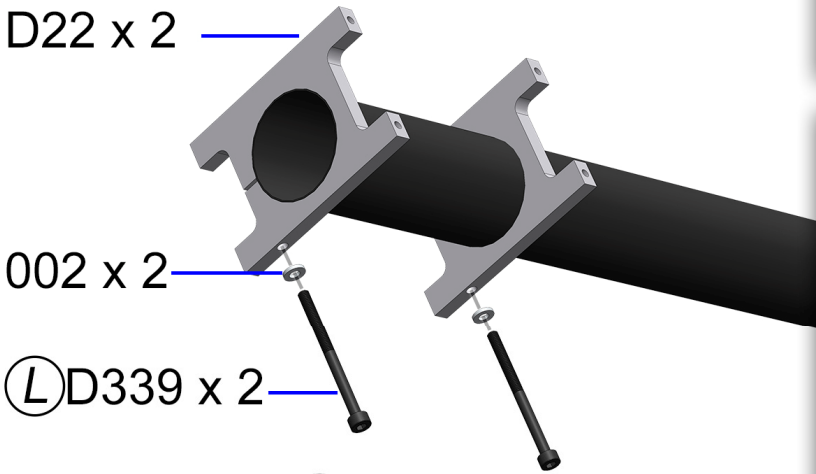
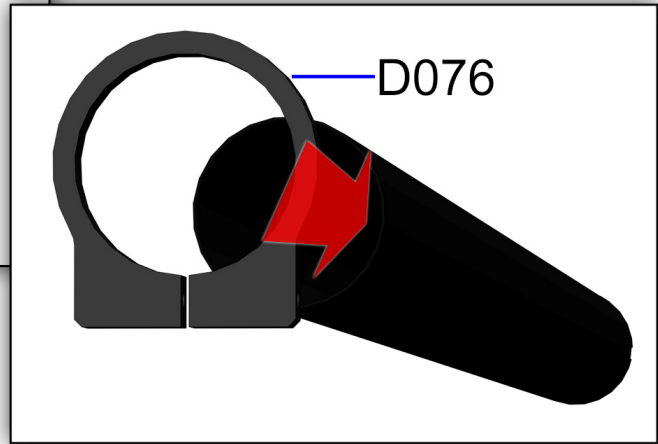
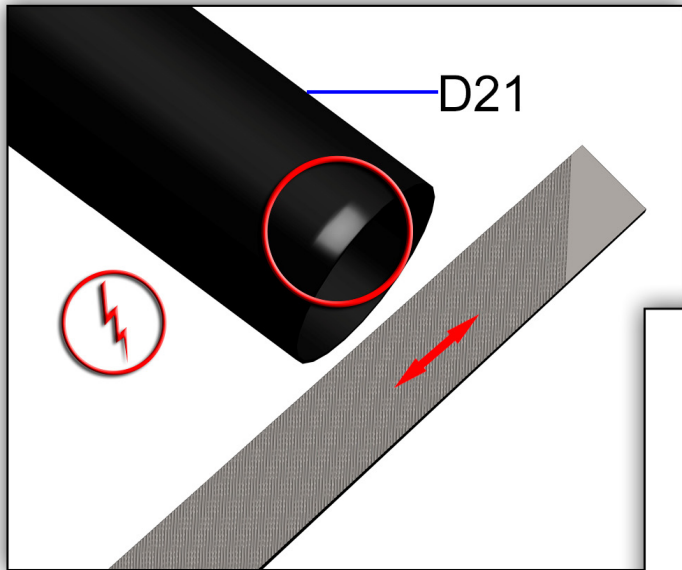

(L) = Loctite 243

*minicopter*

*Diabolo L*

9

Ⓛ D138 x 3

D248a

D248

D248b

Ⓛ D356 x 3

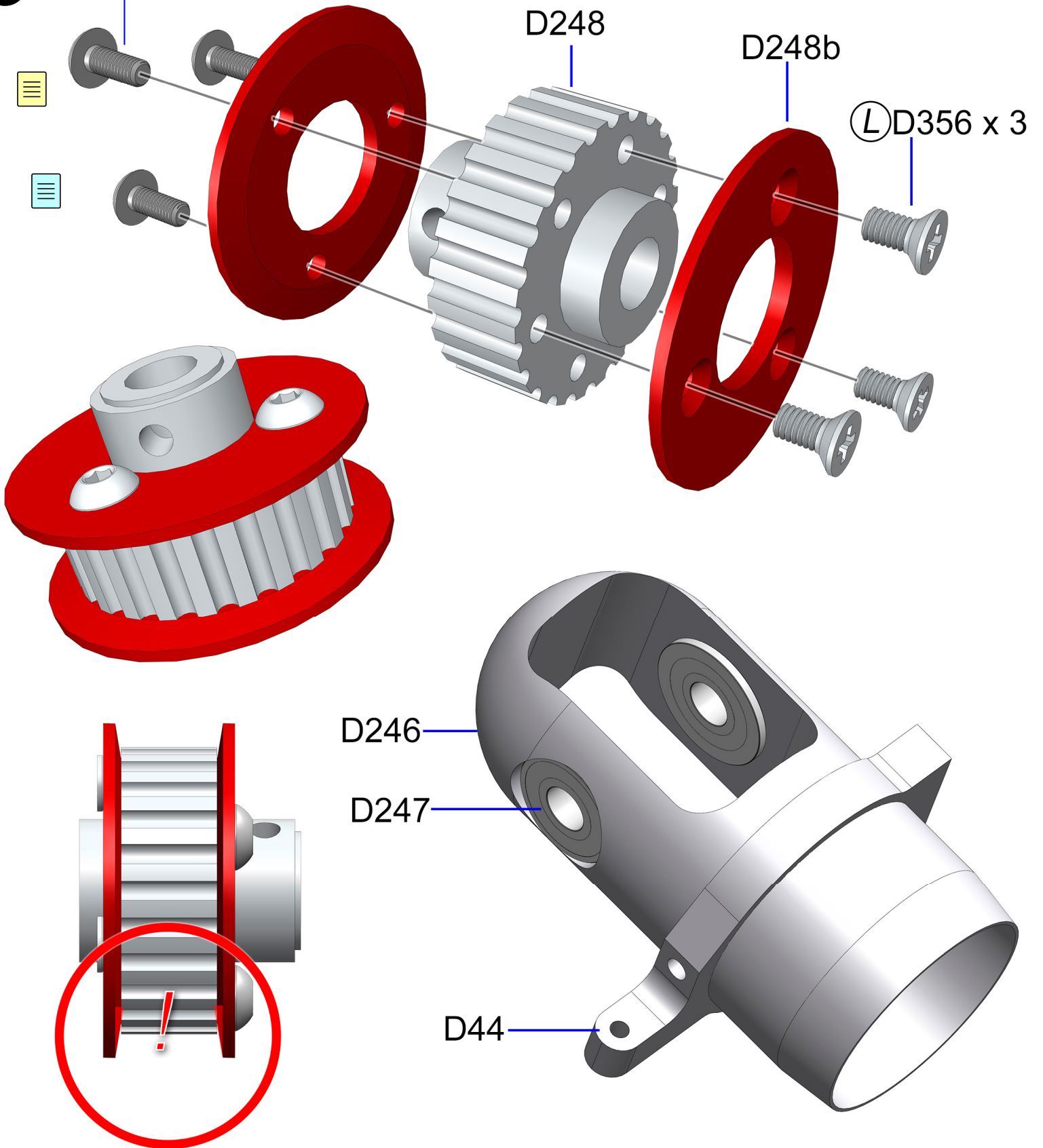

Ⓛ = Loctite 243

*minicopter*

*Diabolo L*

# 10

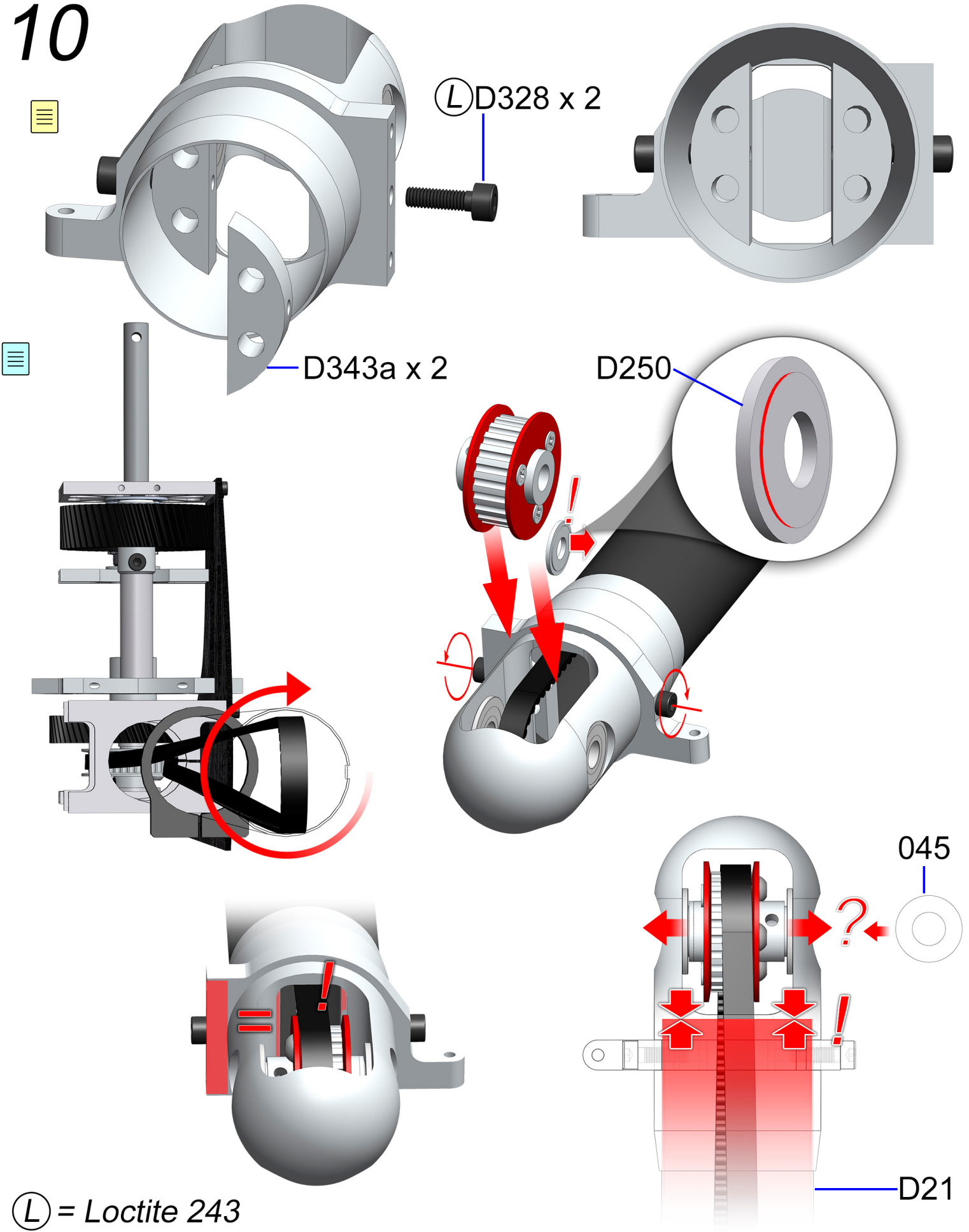

(L) = Loctite 243

*minicopter*

*Diabolo L*



11

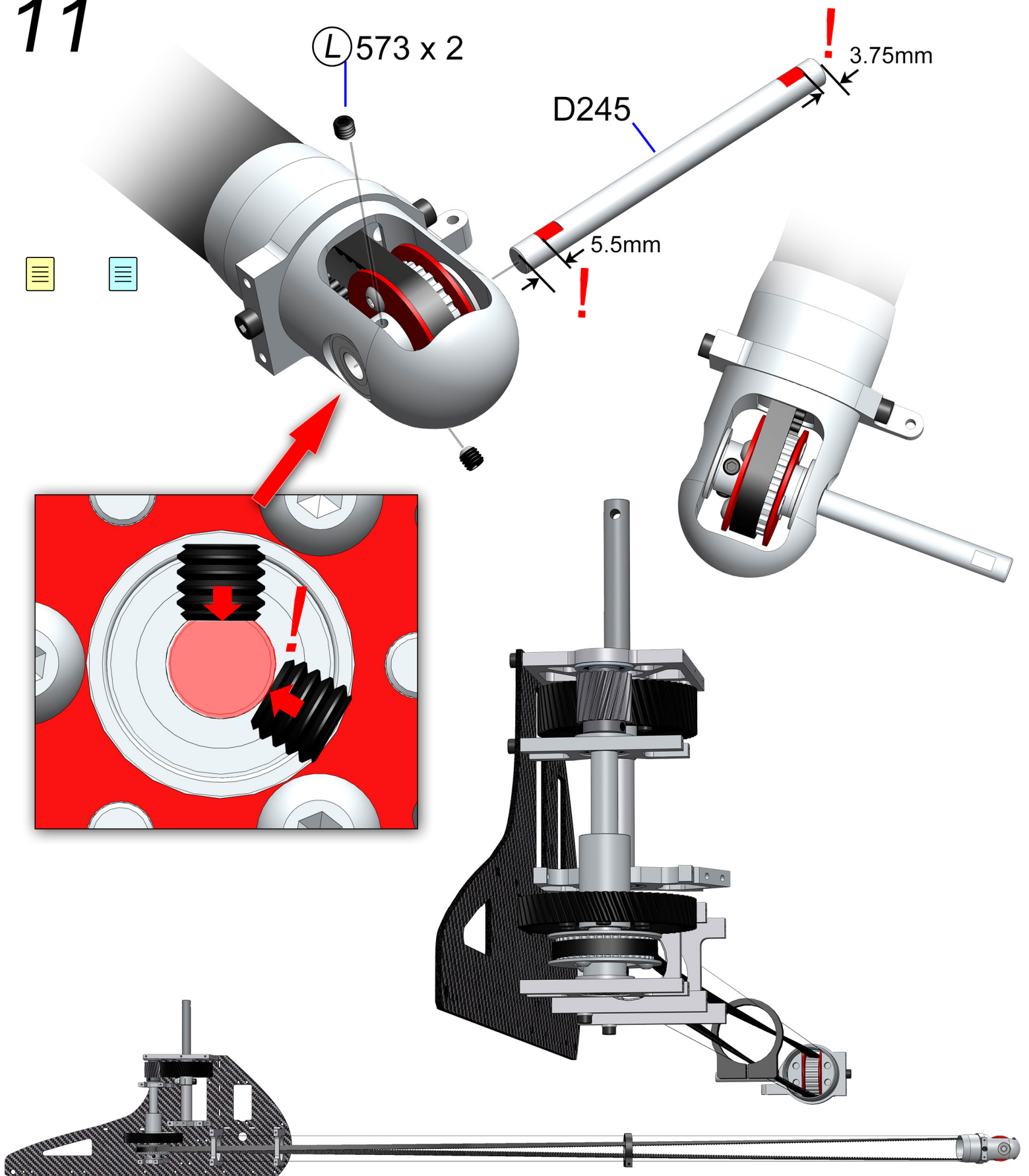

(L) = Loctite 243

*minicopter*

*Diabolo L*



12



D18

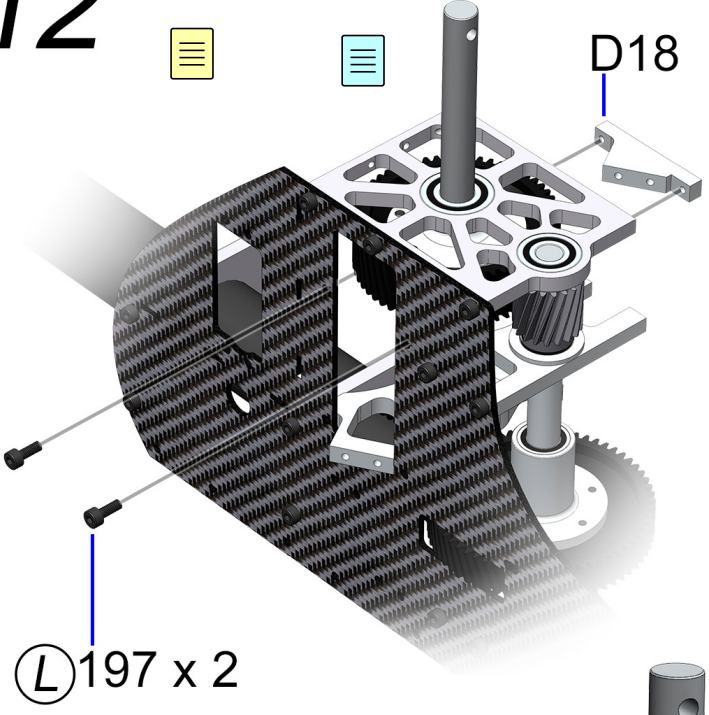

(L)197 x 2

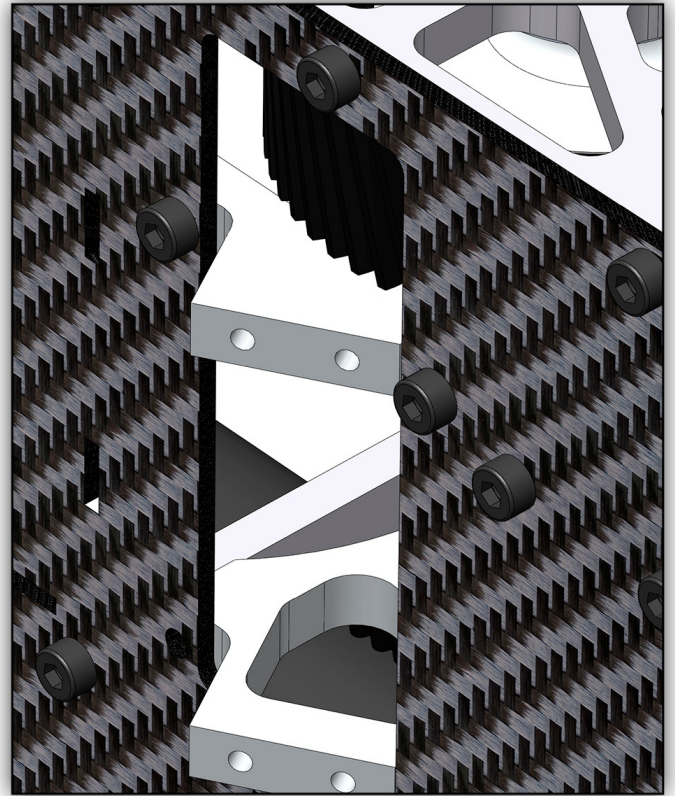

D428

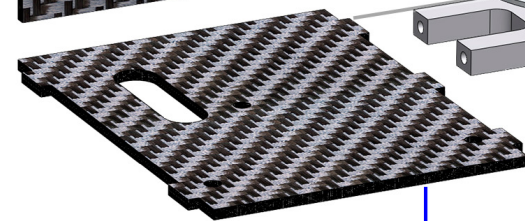
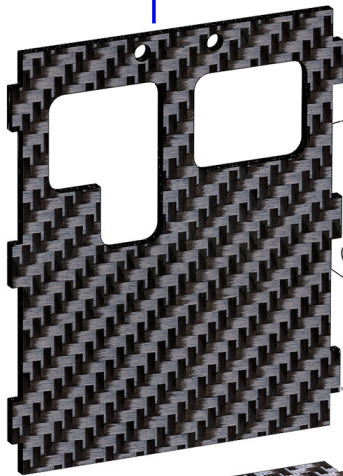

D427

(L) = Loctite 243

(L)197

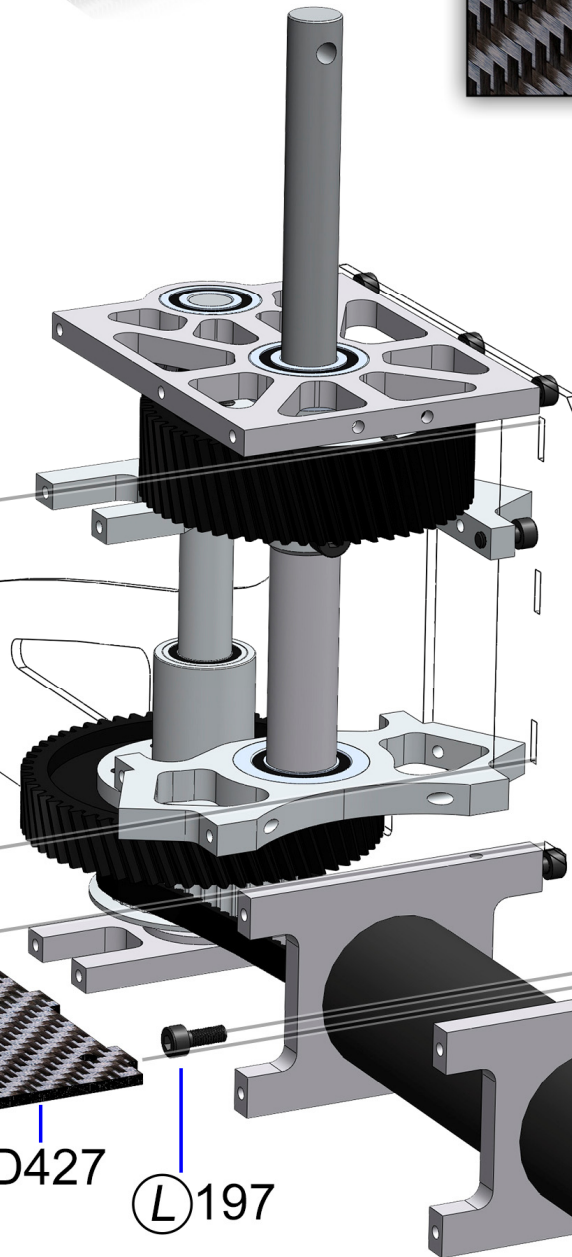

D63

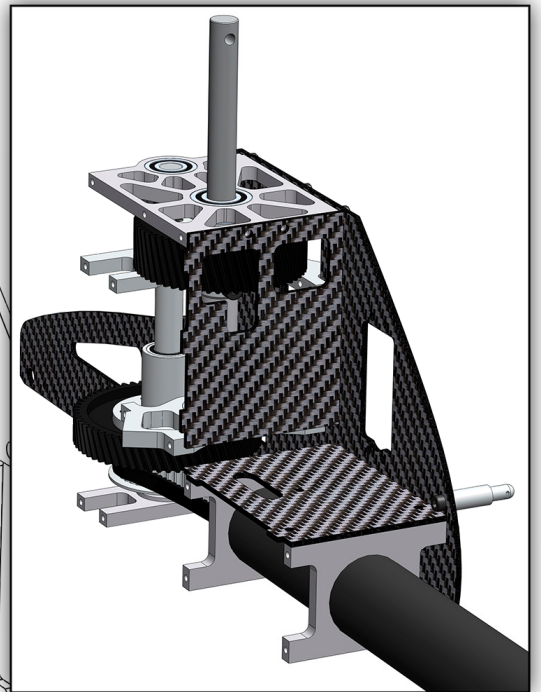

*minicopter*

*Diabolo L*

13

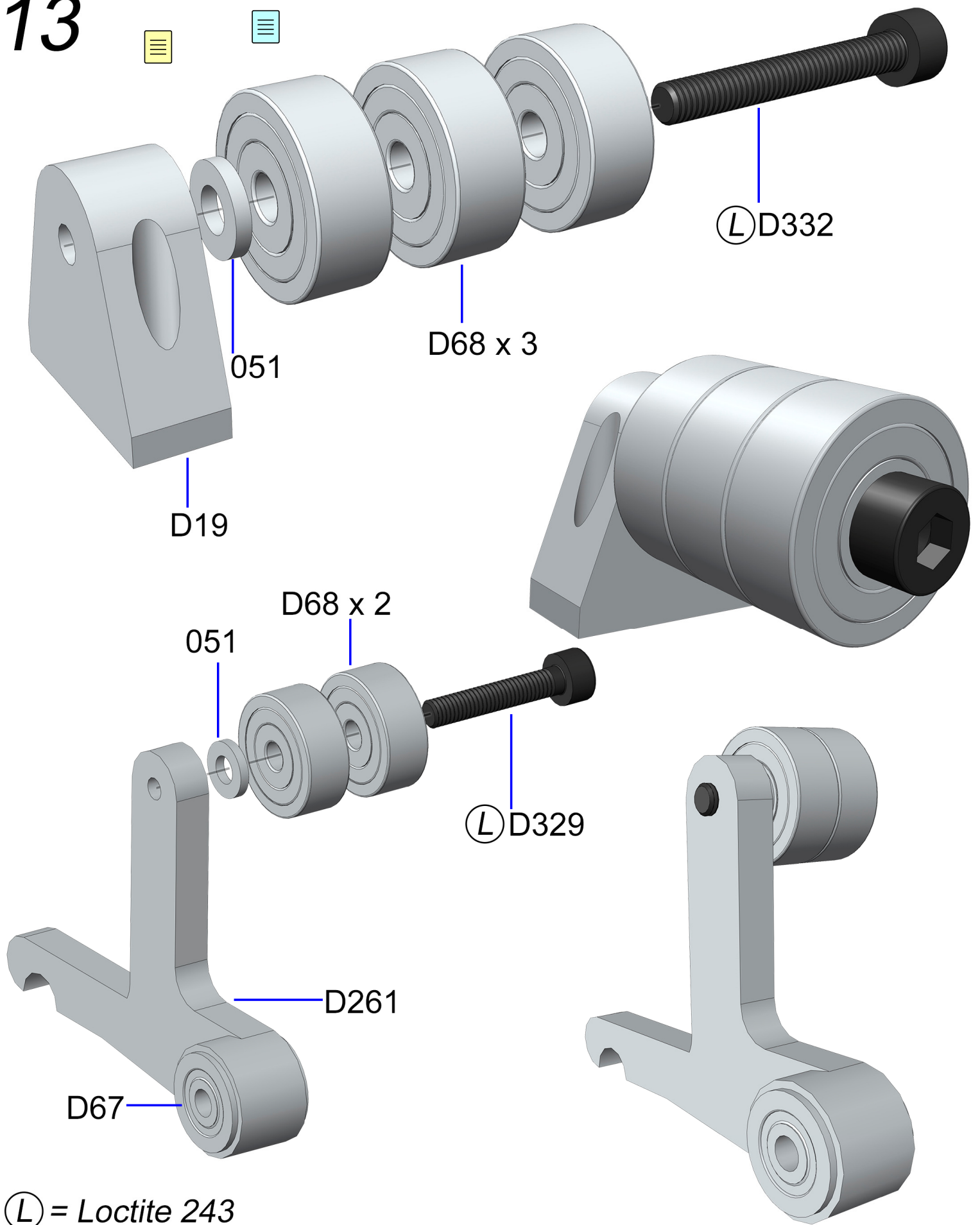

(L) = Loctite 243

*minicopter*

*Diabolo L*



14

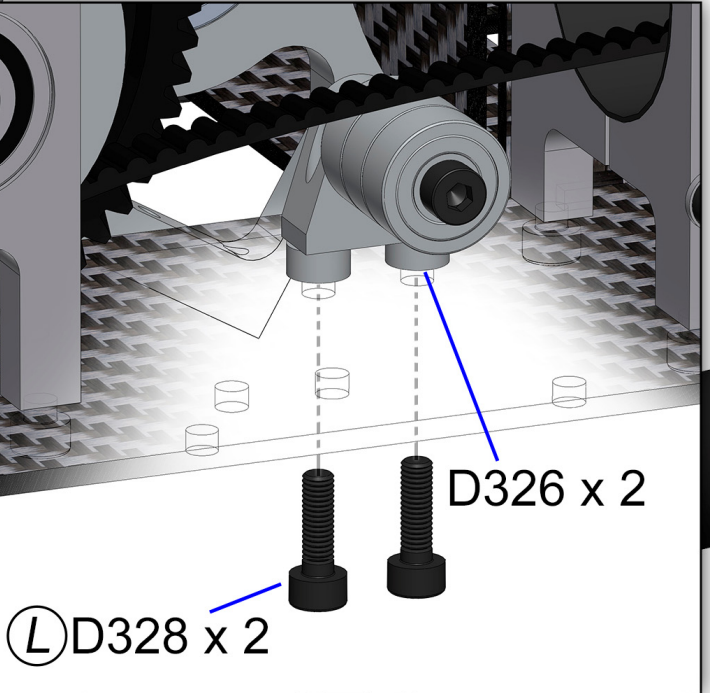
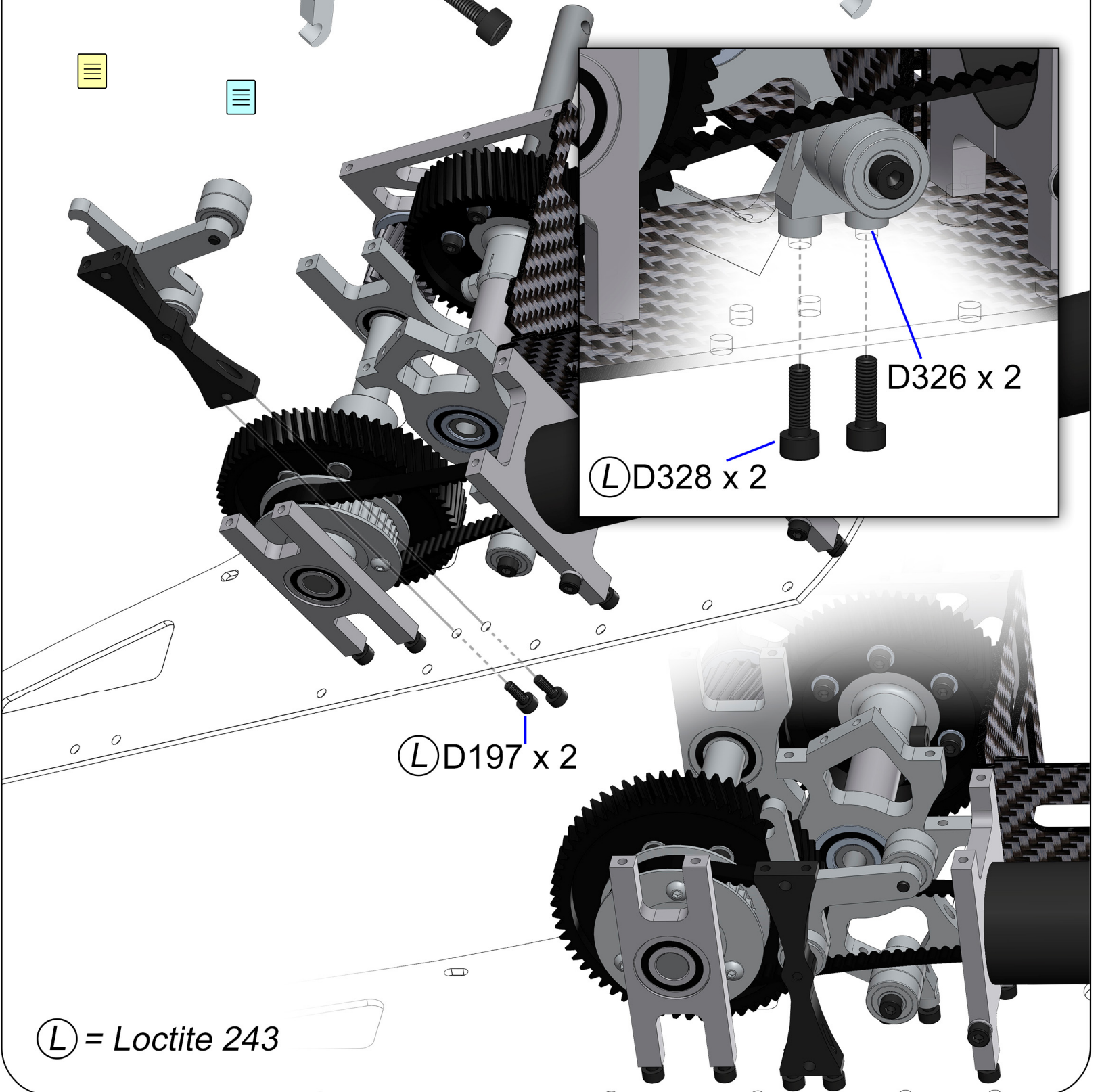
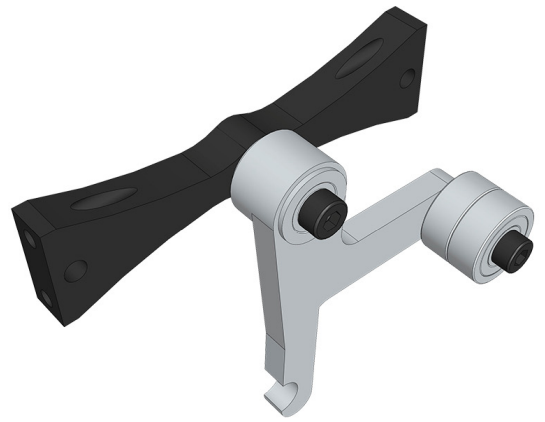
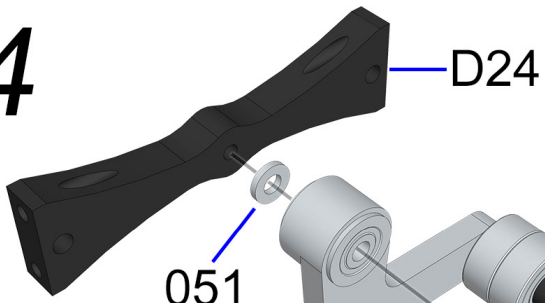

(L) = Loctite 243

*minicopter*

*Diabolo L*

# 15

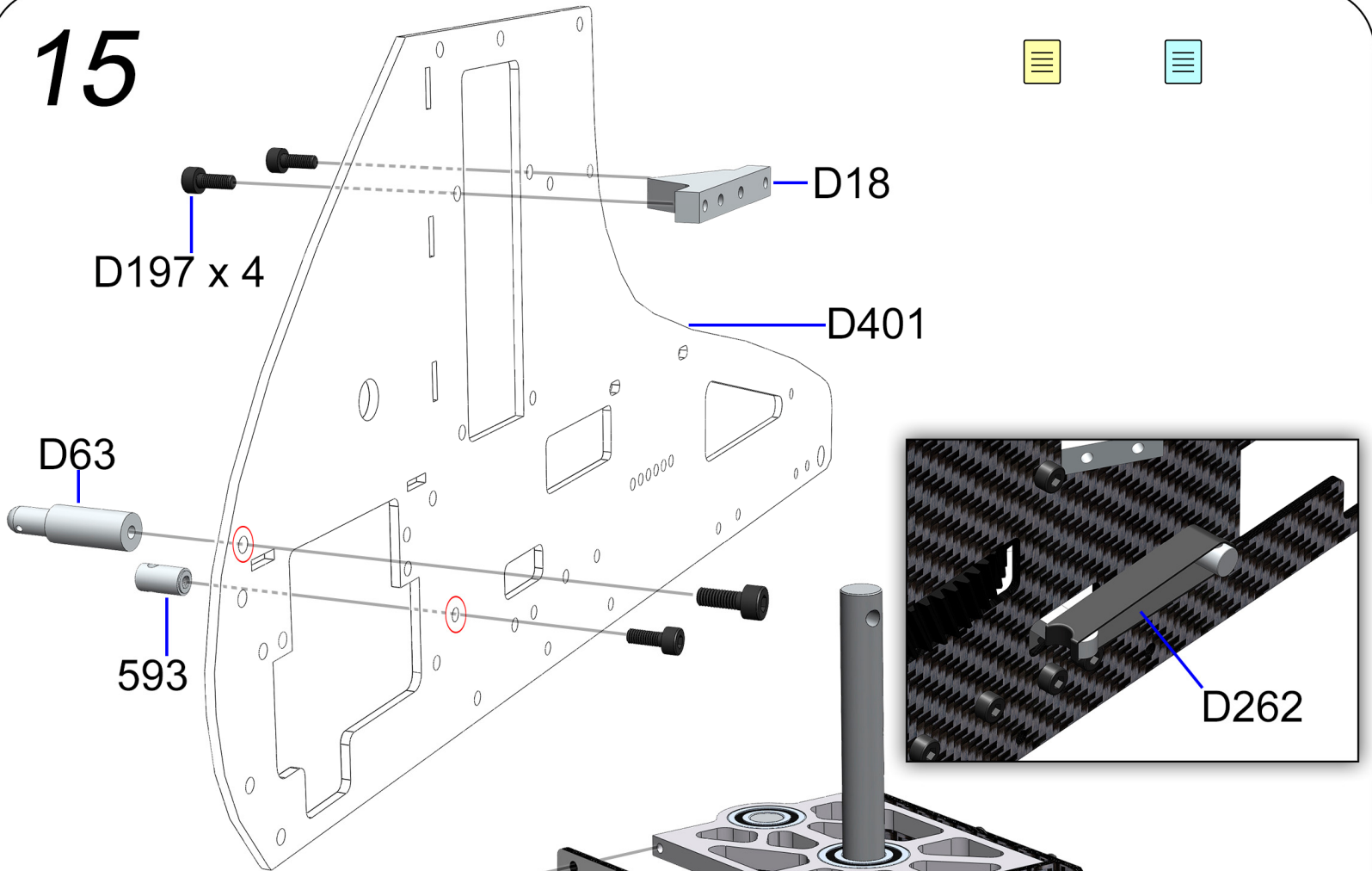

Ⓛ D197 x 15

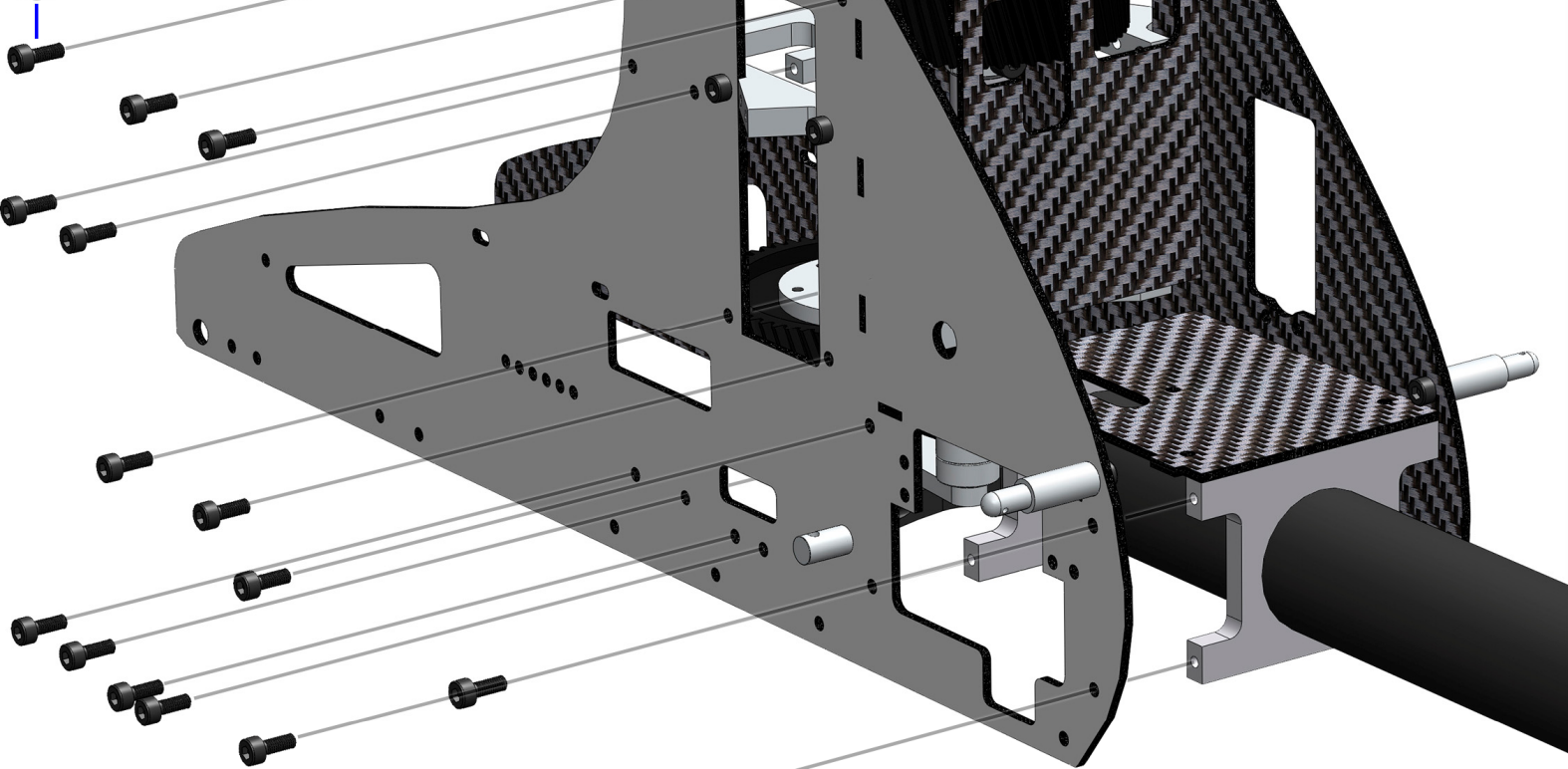

Ⓛ = Loctite 243

*minicopter*

*Diabolo L*



16

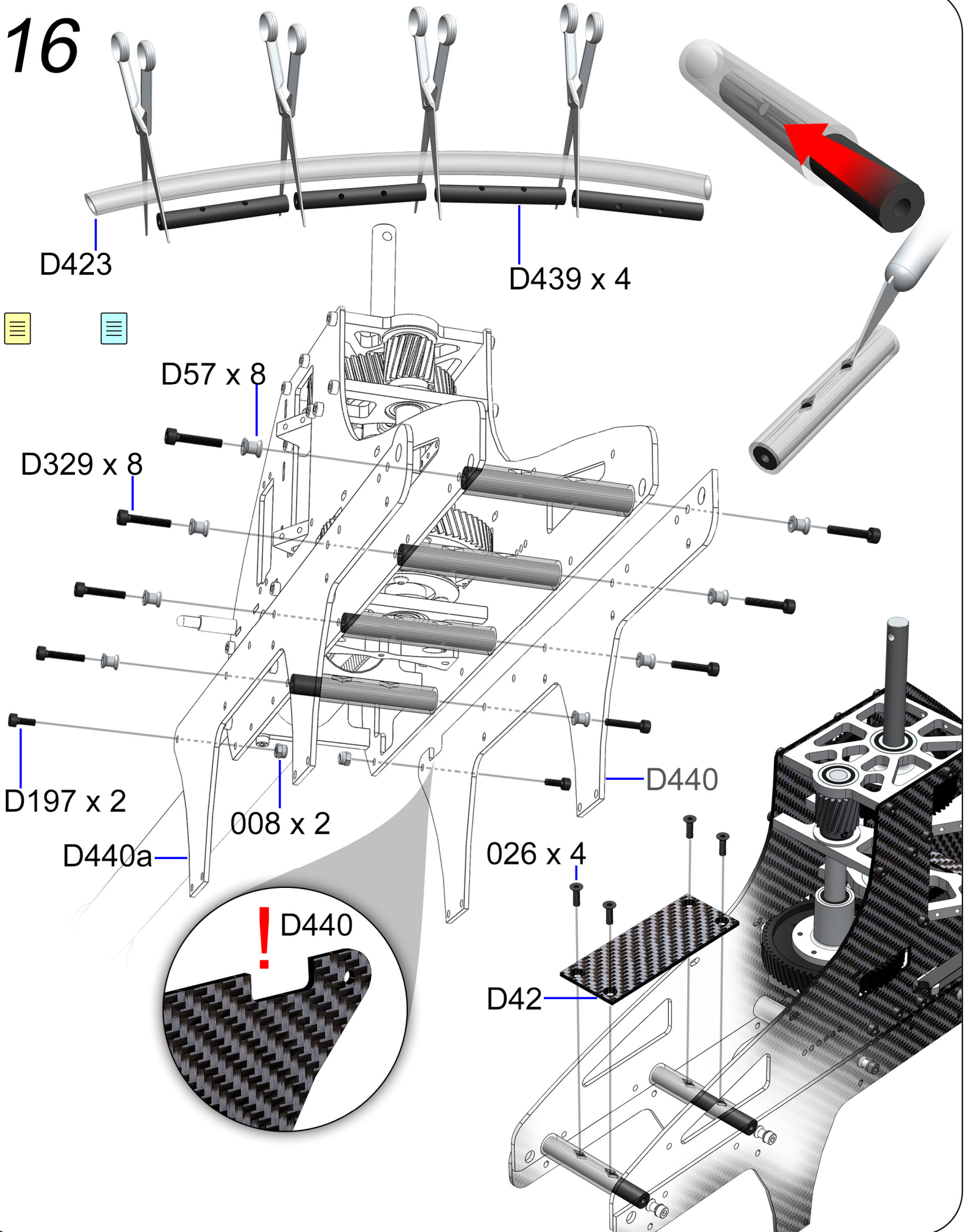

*minicopter*

*Diabolo L*



17



(L) D197 x 6

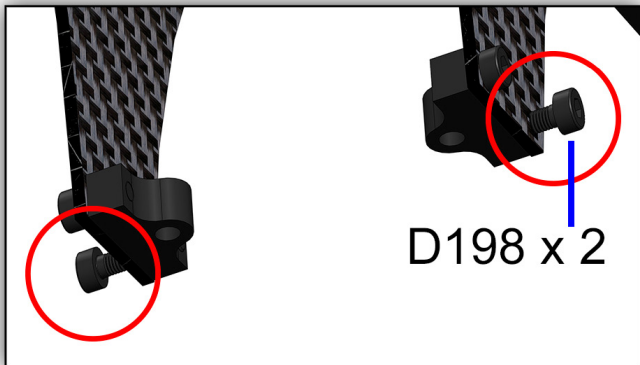

D198 x 2

(L) D198 x 2

D441 x 4

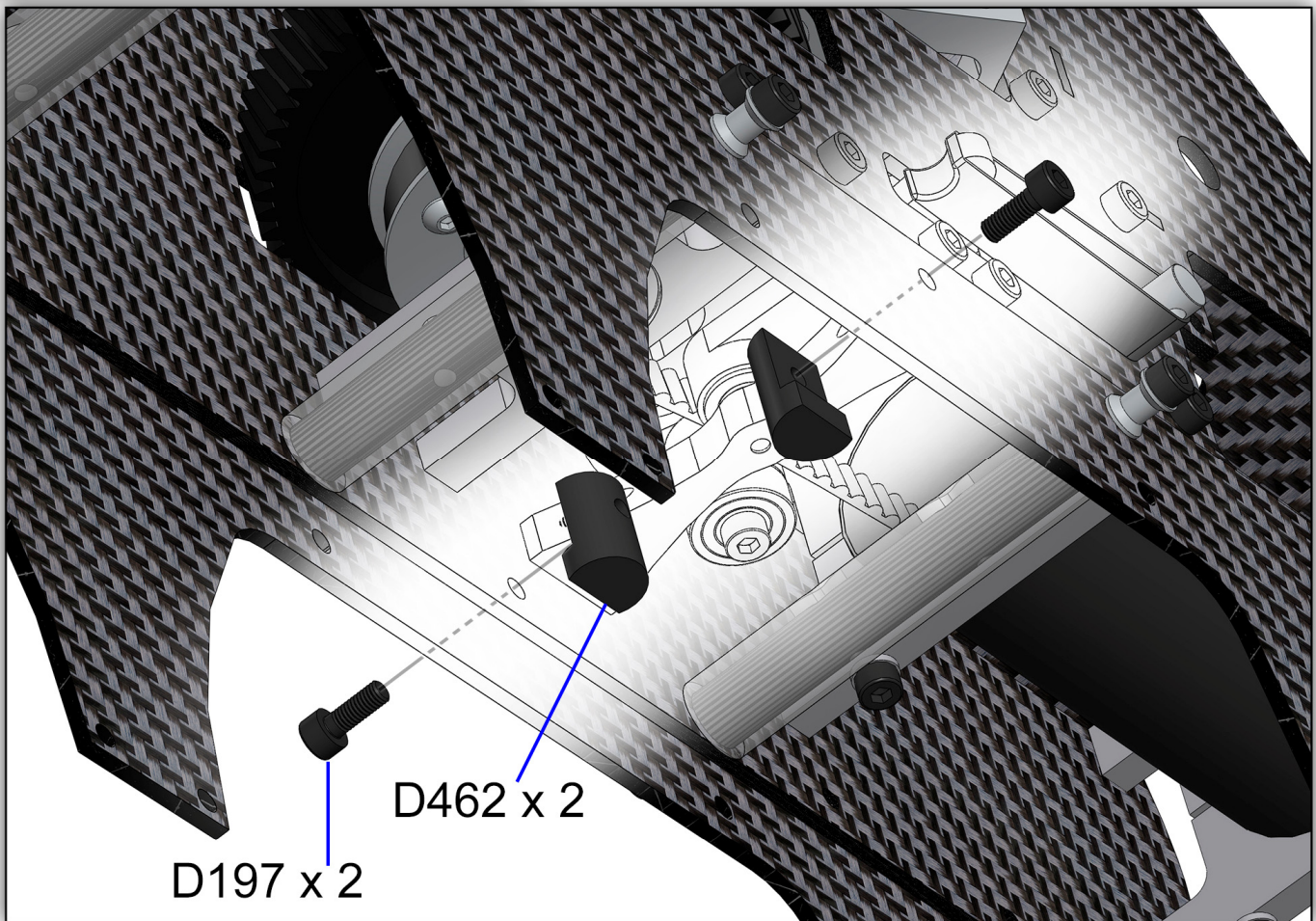

D462 x 2

D197 x 2

(L) = Loctite 243

*minicopter*

*Diabolo L*



18

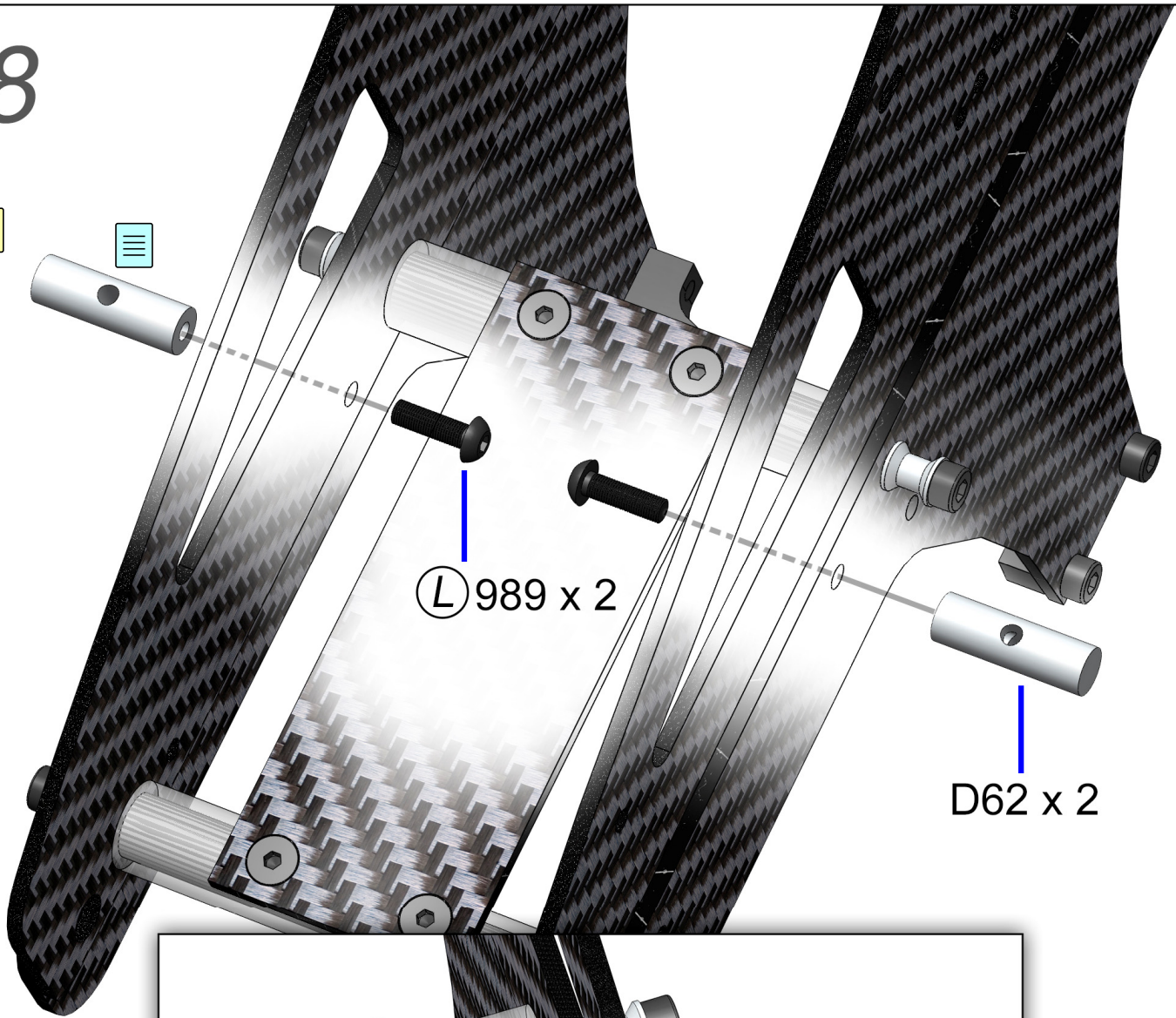

Ⓛ 989 x 2

D62 x 2

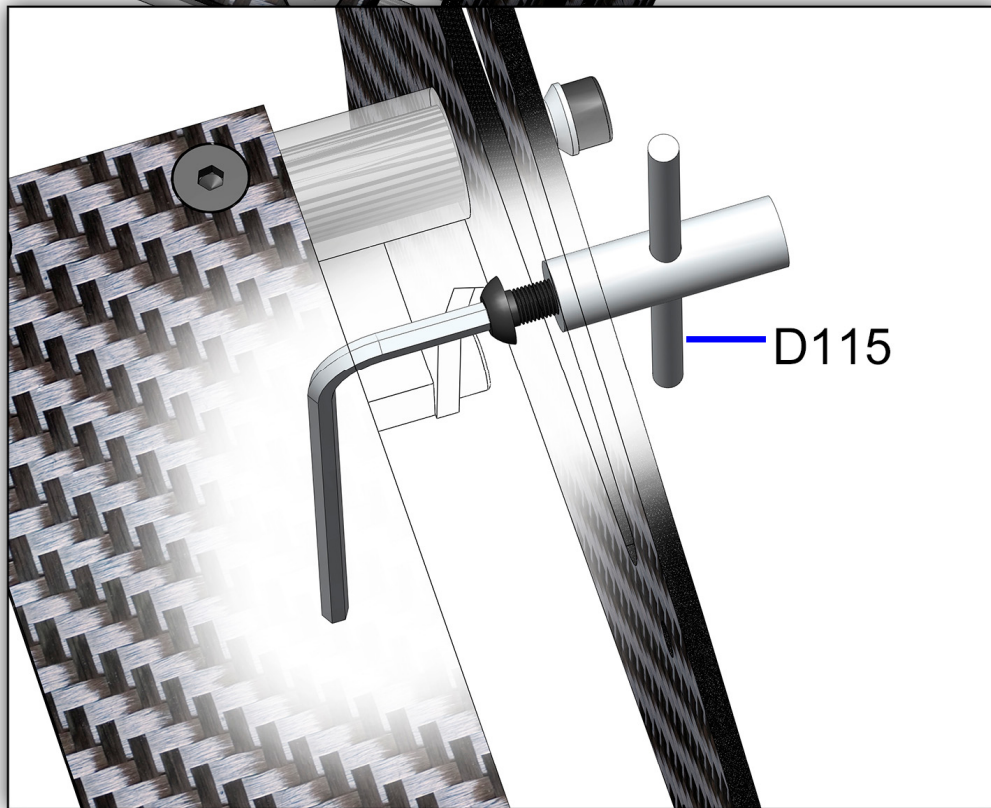

D115

Ⓛ = Loctite 243

*minicopter*

*Diabolo L*



19

(L) D106 x 4

(L) 035 x 2

D36

(L) D197 x 4

002 x 4

(L) = Loctite 243

*minicopter*

*Diabolo L*

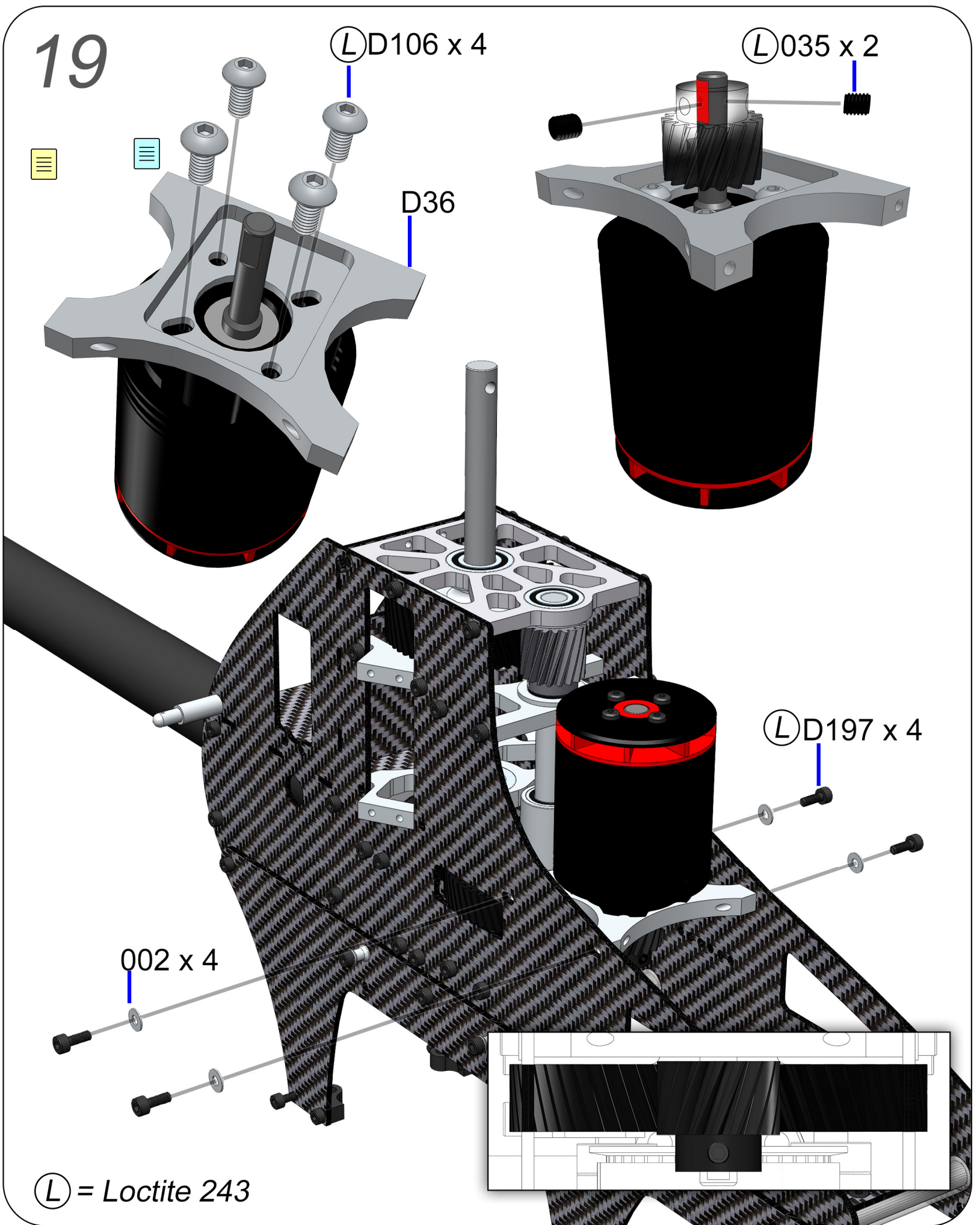



20



D442 x 2

D129

D129

(L) 024 x 4

D492 x 2

D547 x 4

(L) D107 x 4

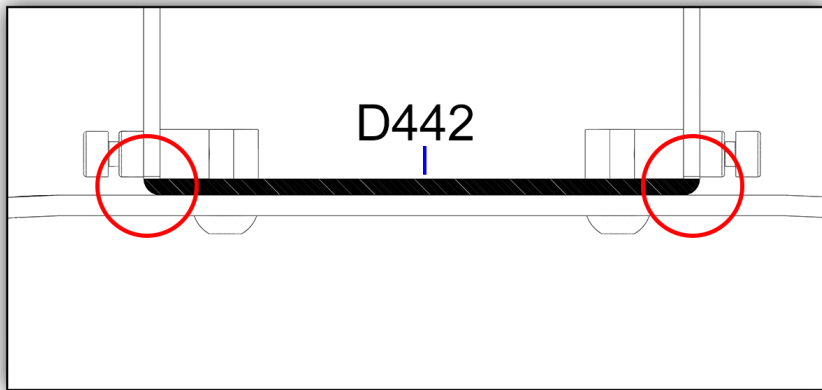

D442

(L) D197 x 2

D48

(L) = Loctite 243

*minicopter*

*Diabolo L*

21

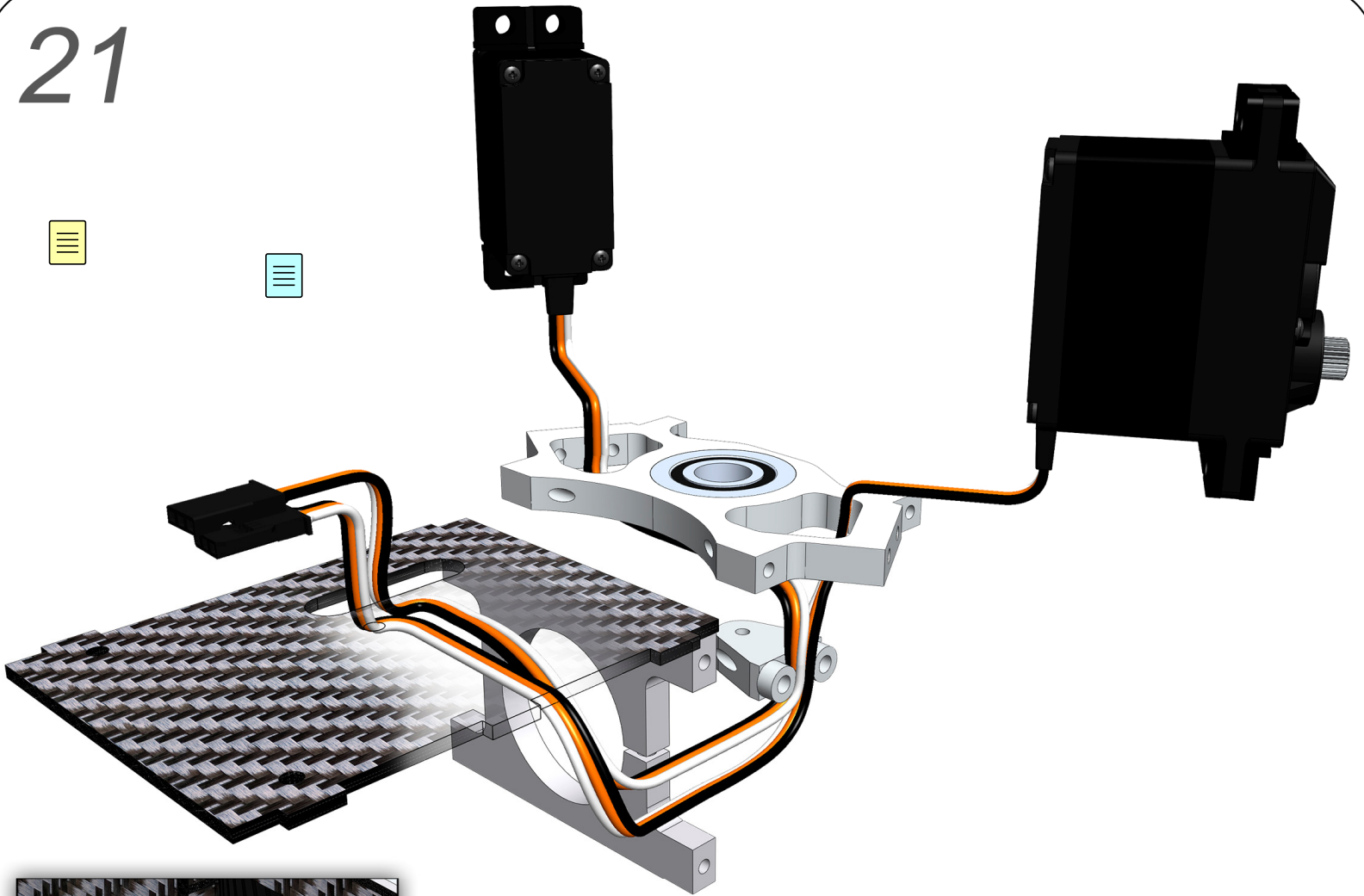

Ⓛ D119 x 4

002 x 4

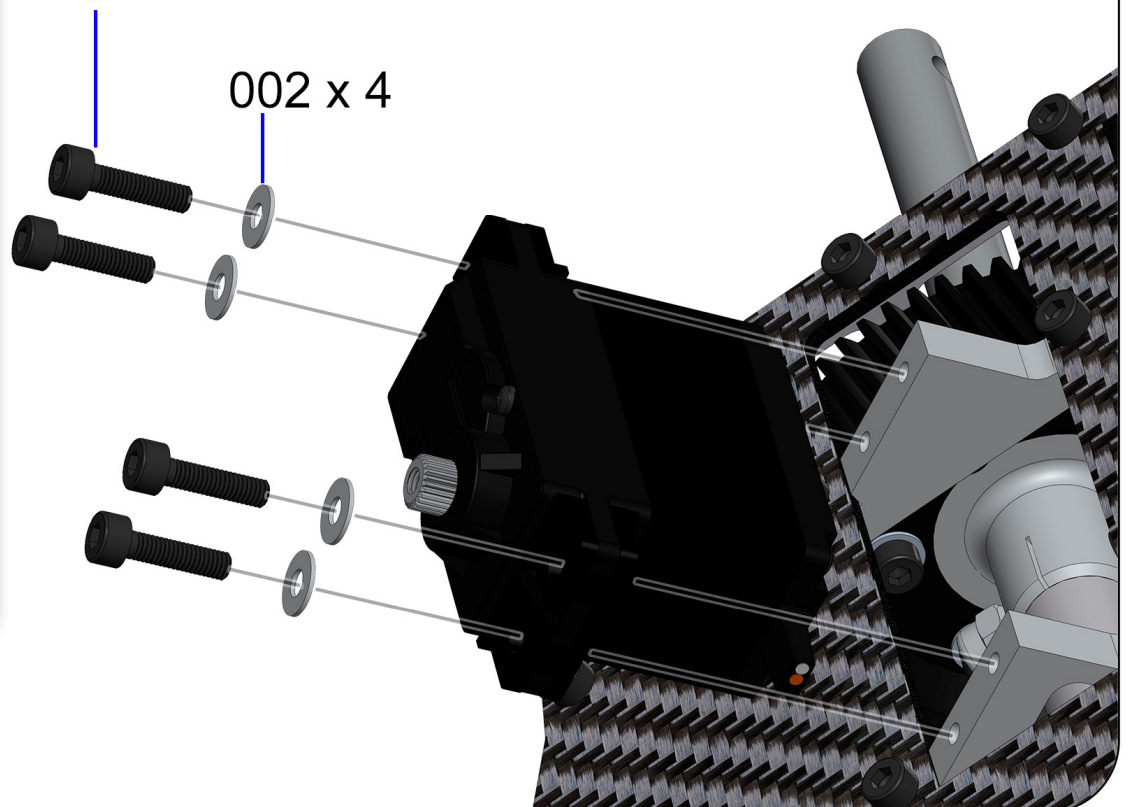

Ⓛ = Loctite 243

*minicopter*

*Diabolo L*



22

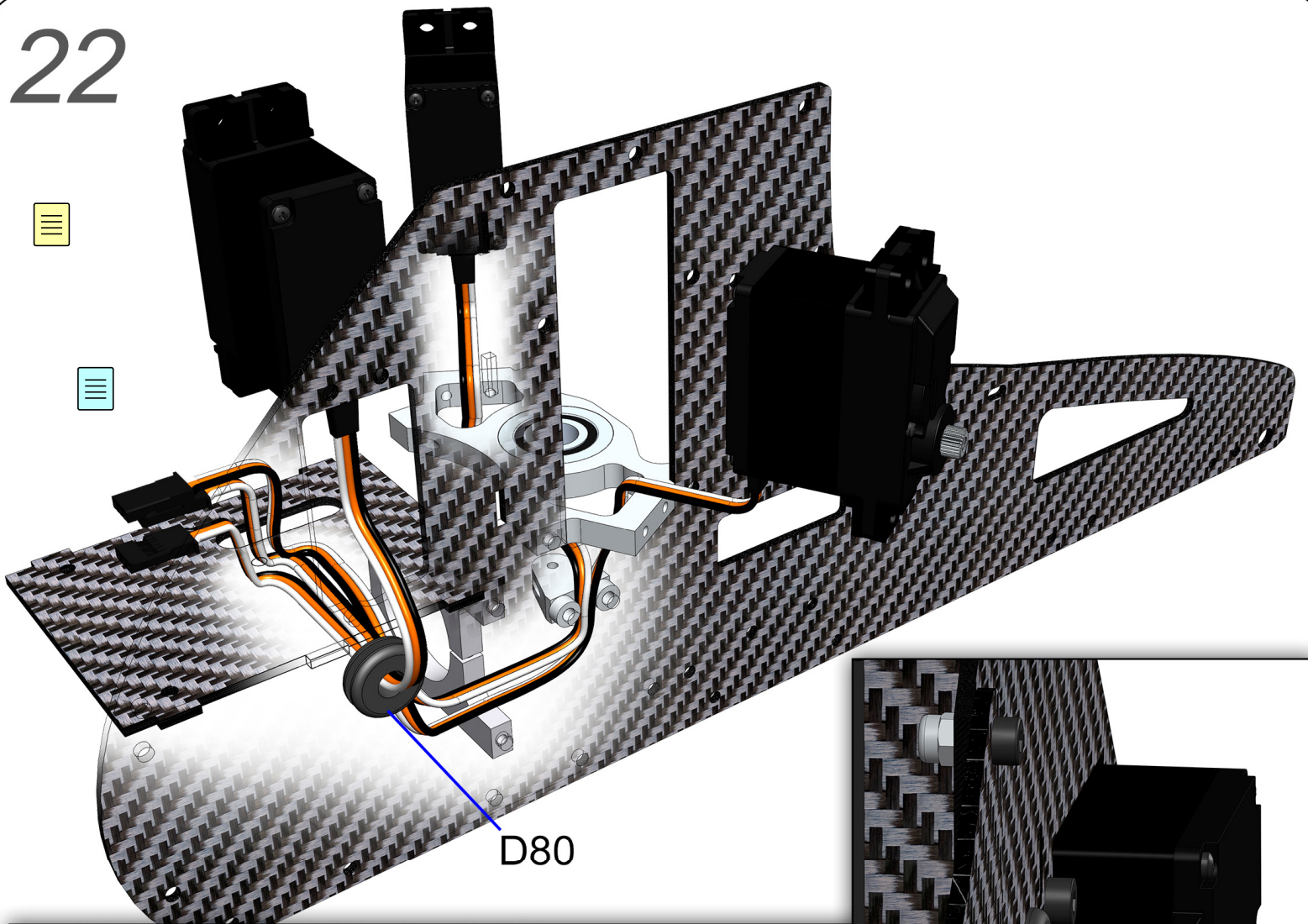

D80

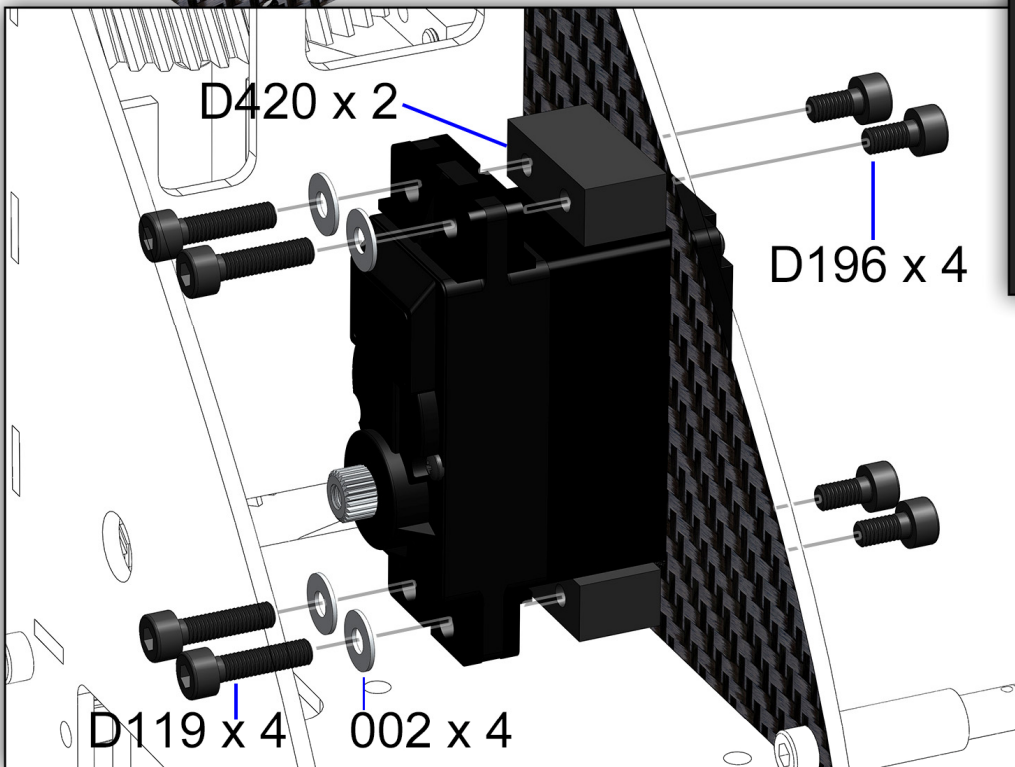
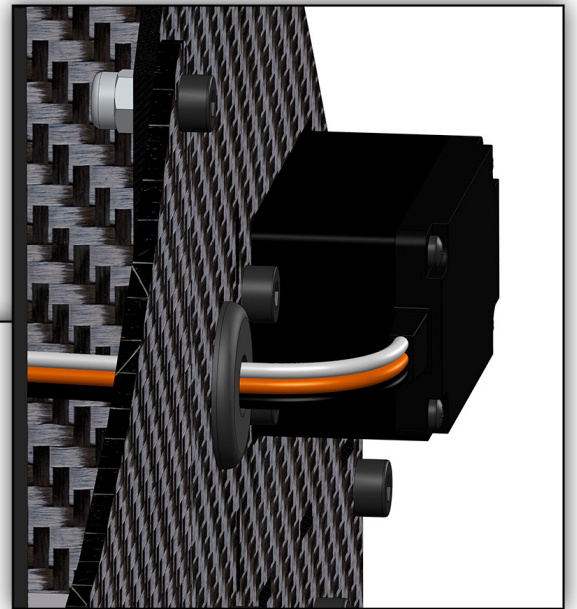

*minicopter*

*Diabolo L*

23

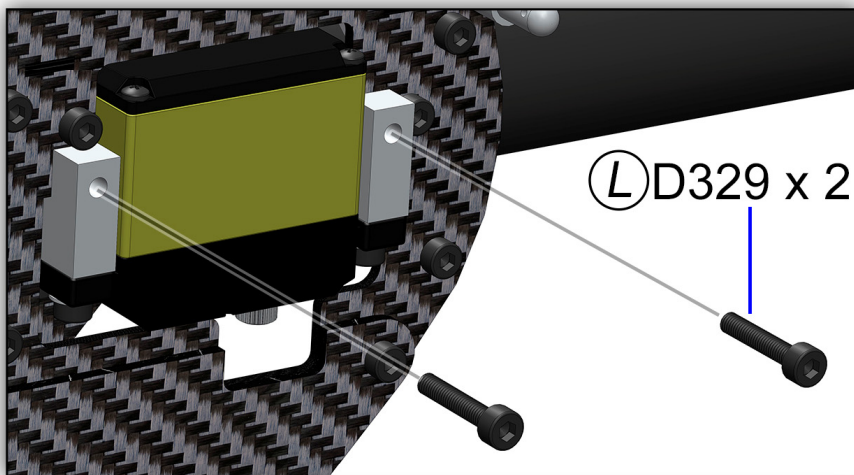
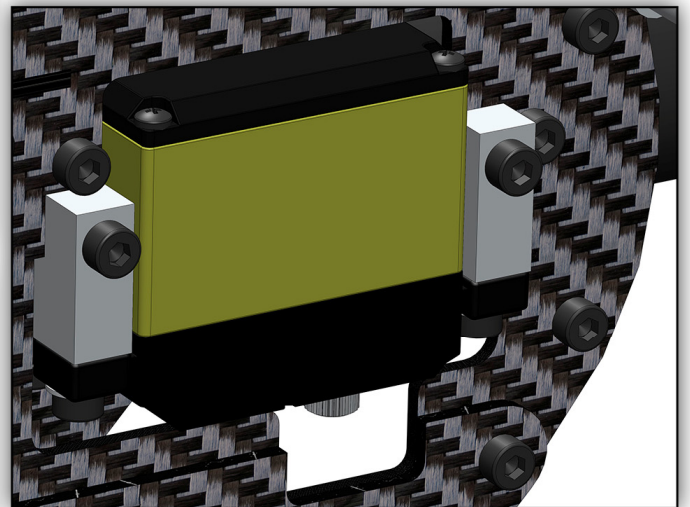
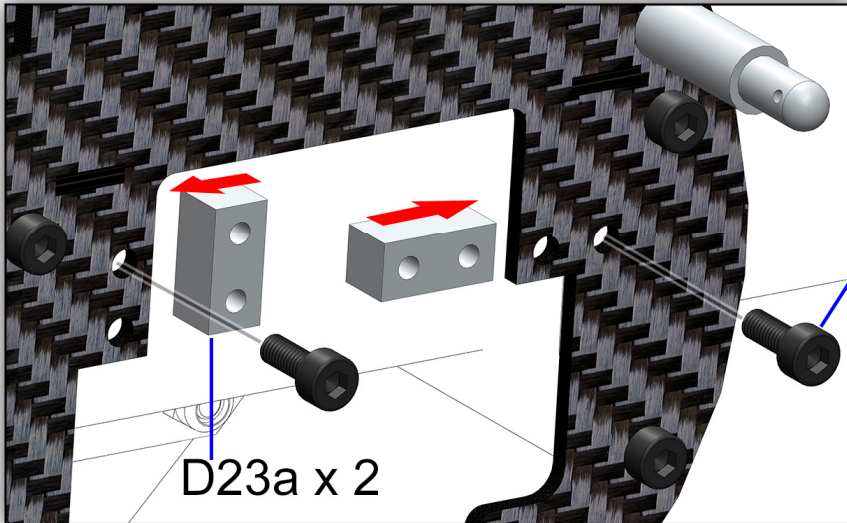
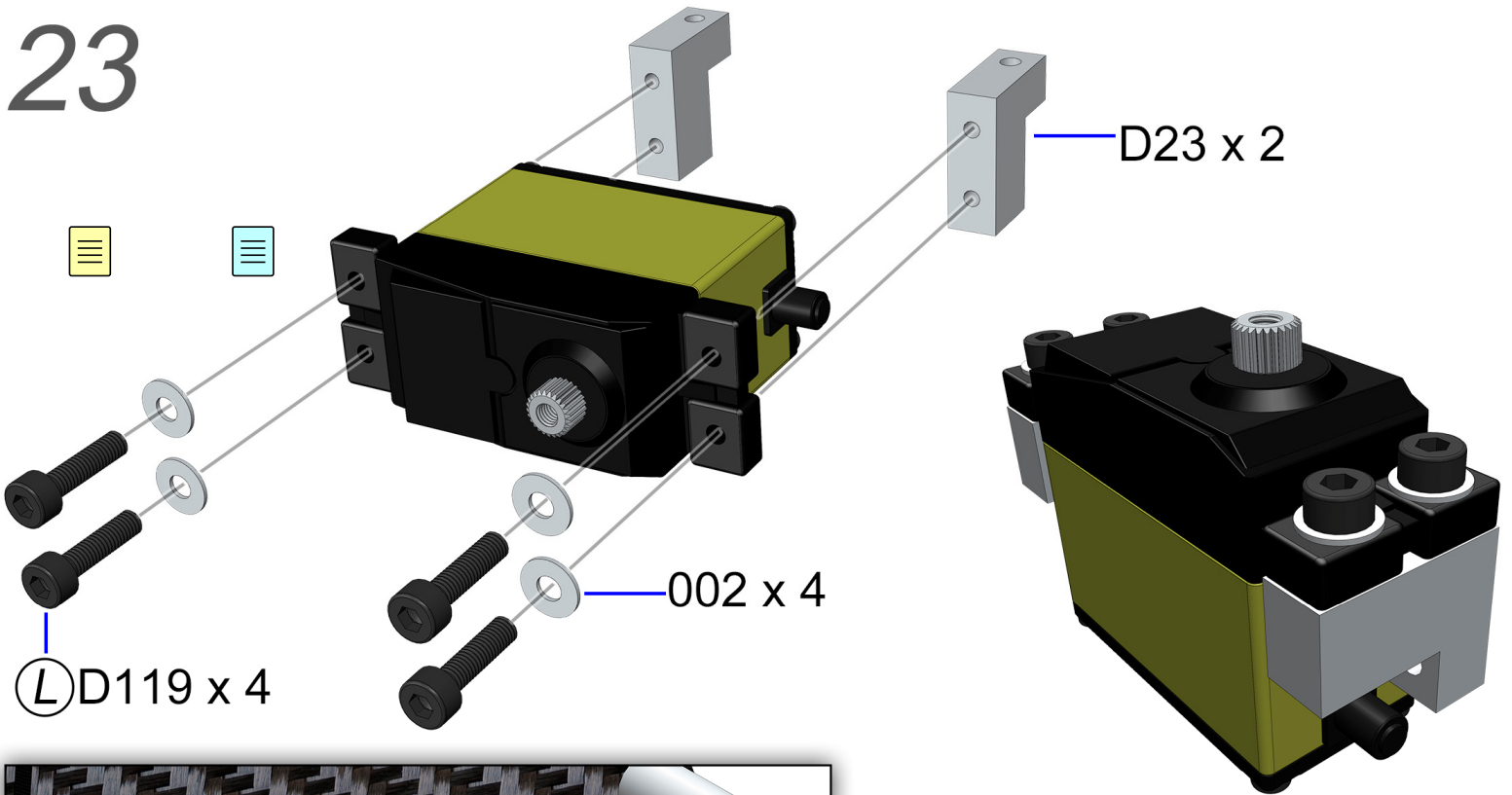

L = Loctite 243

*minicopter*

*Diabolo L*



24

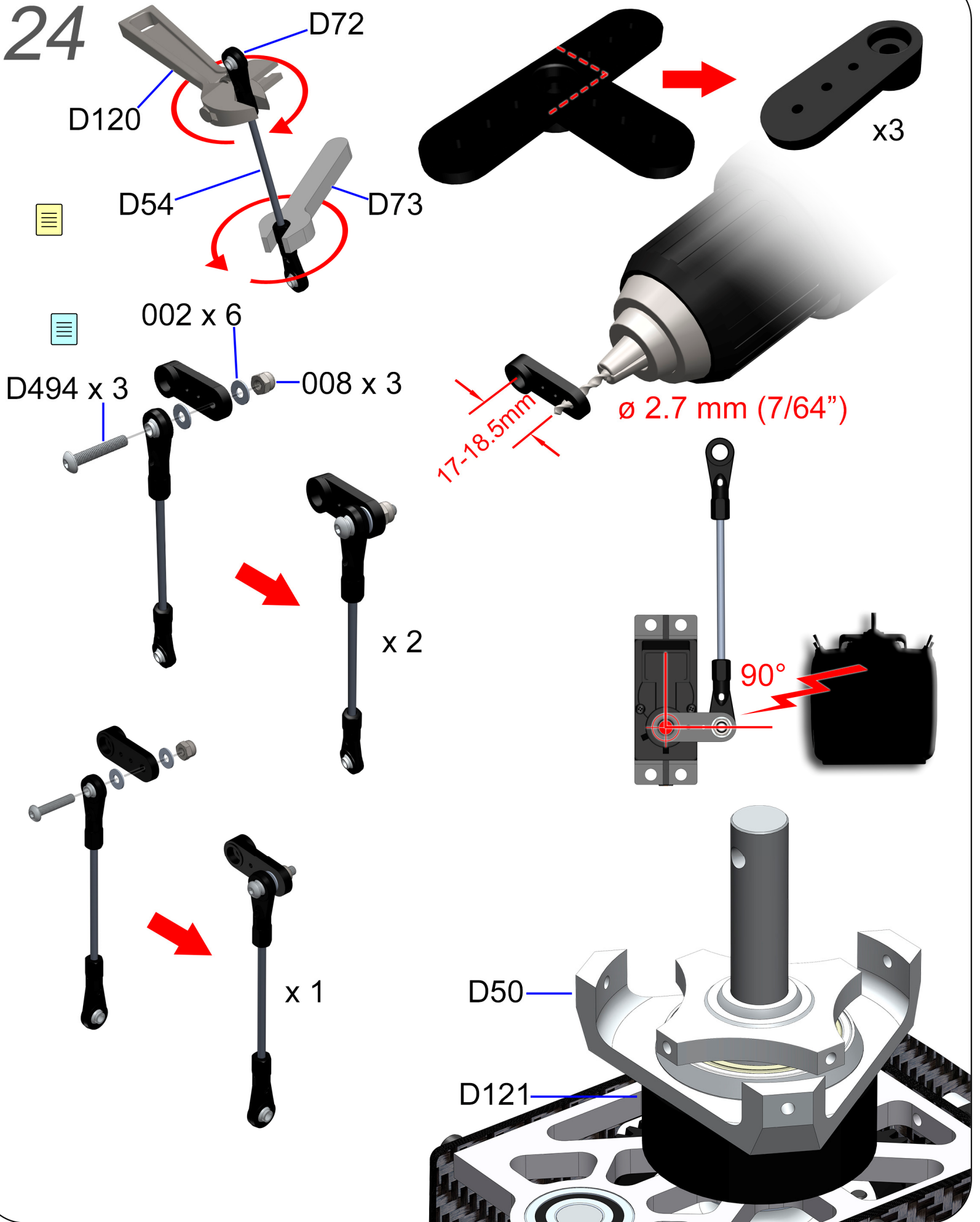

*minicopter*

*Diabolo L*





# 26

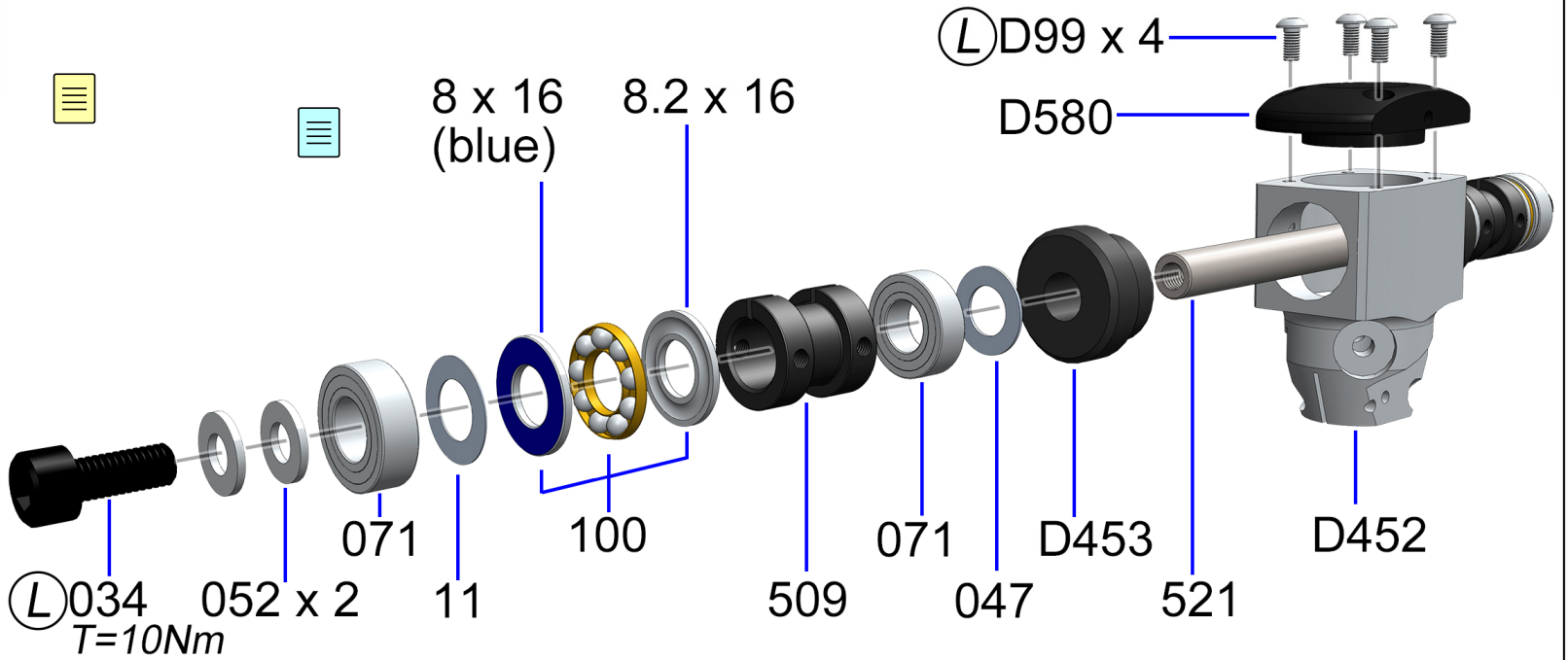

$\textcircled{L}$  = Loctite 243

*minicopter*

*Diabolo L*

27

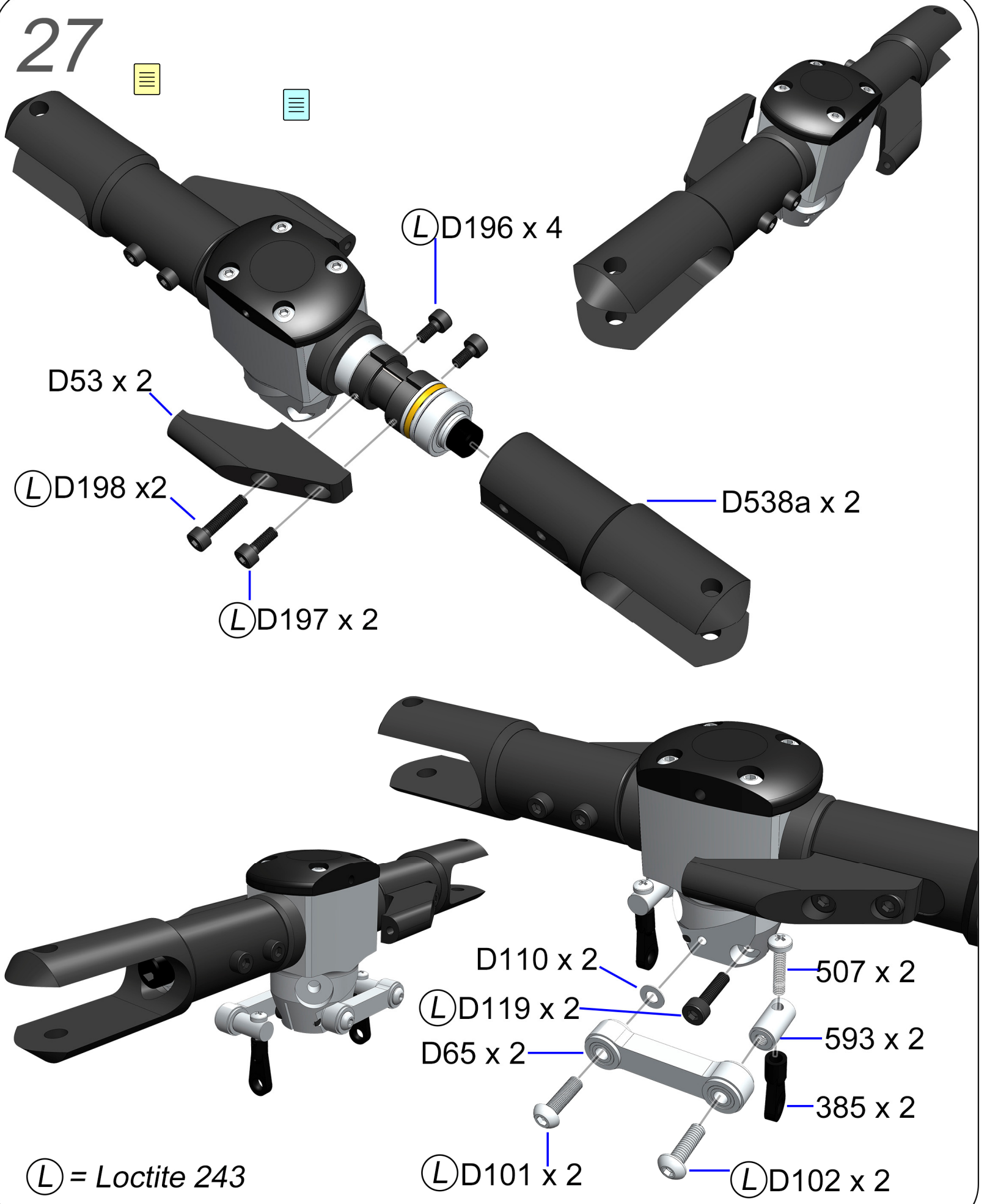

*minicopter*

*Diabolo L*



28

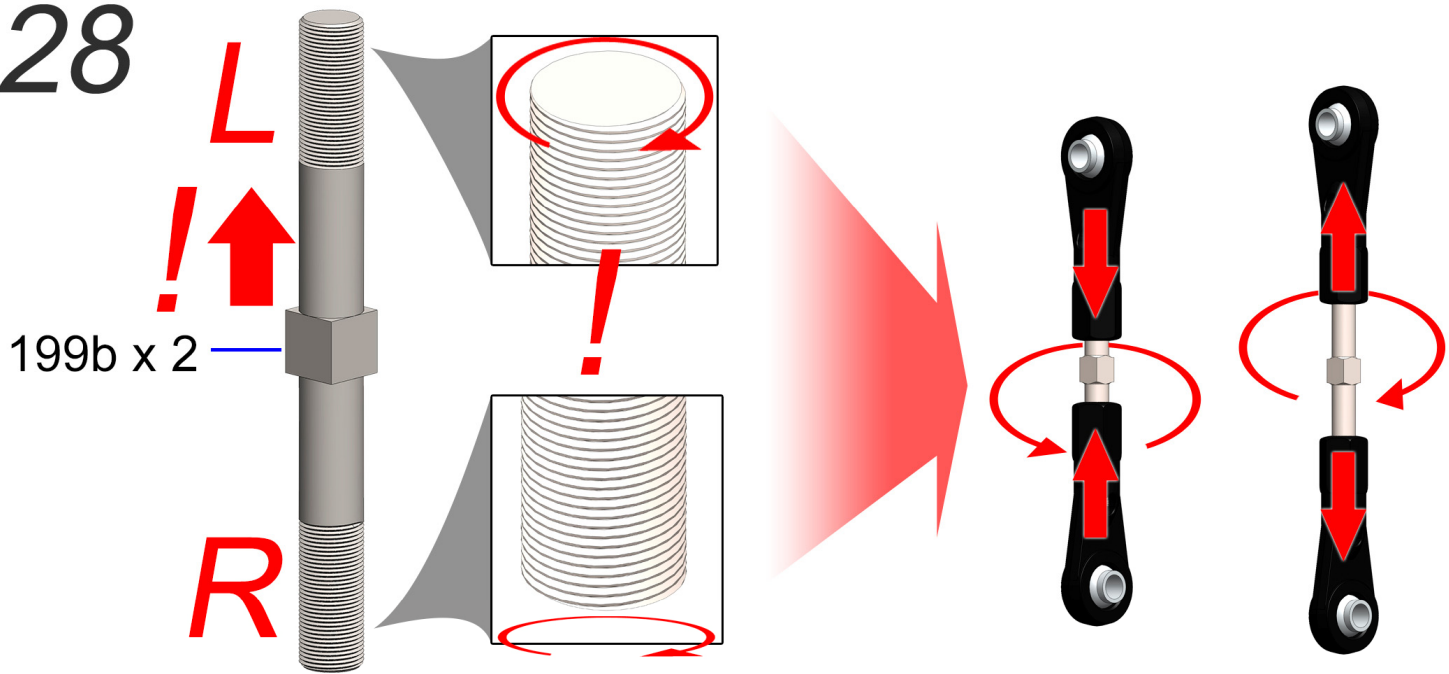

D72 x 4

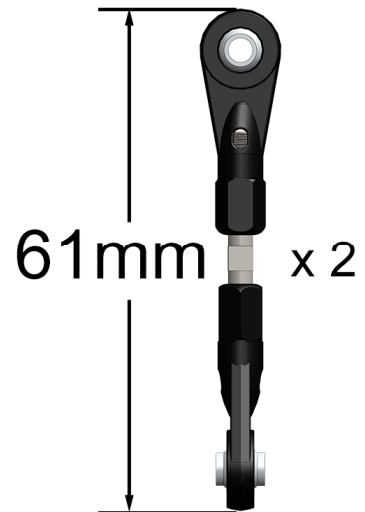
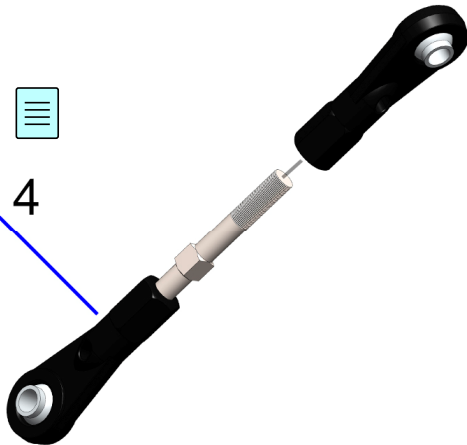

(L) = Loctite 243

(L) 076 x 2

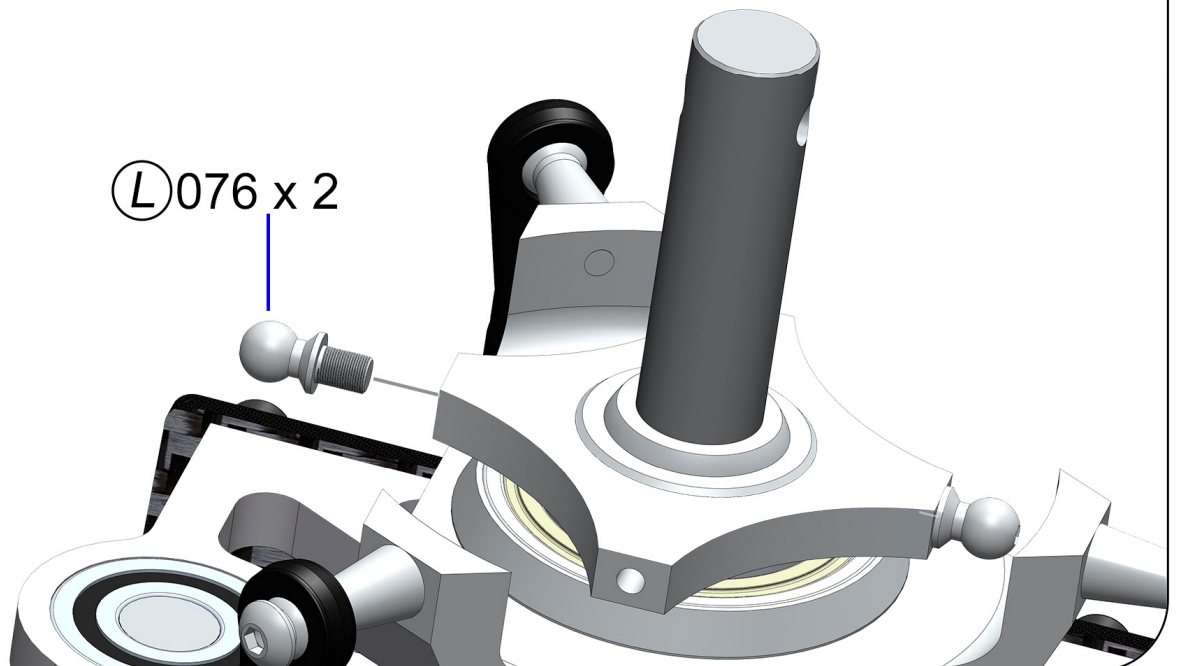

*minicopter*

*Diabolo L*

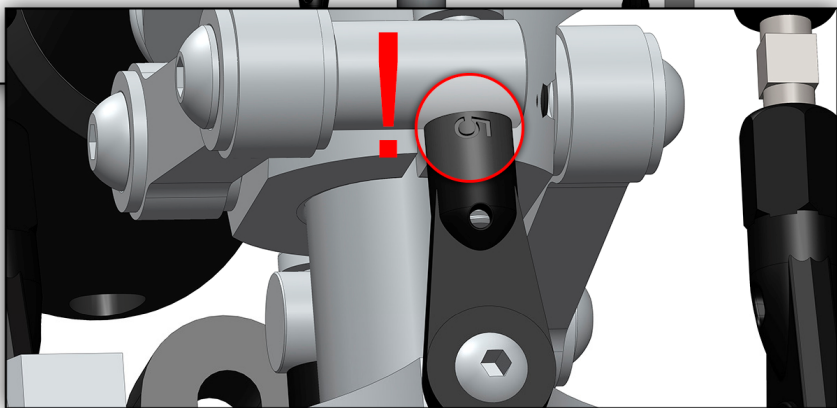
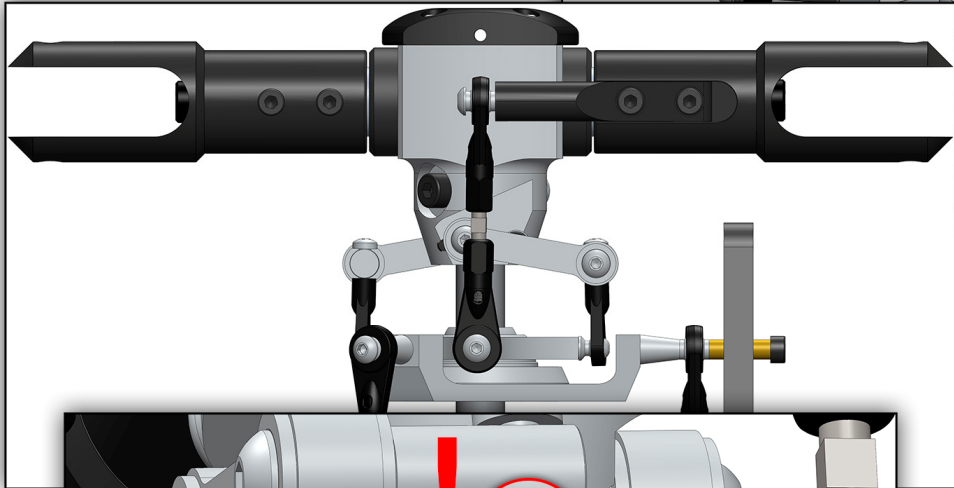
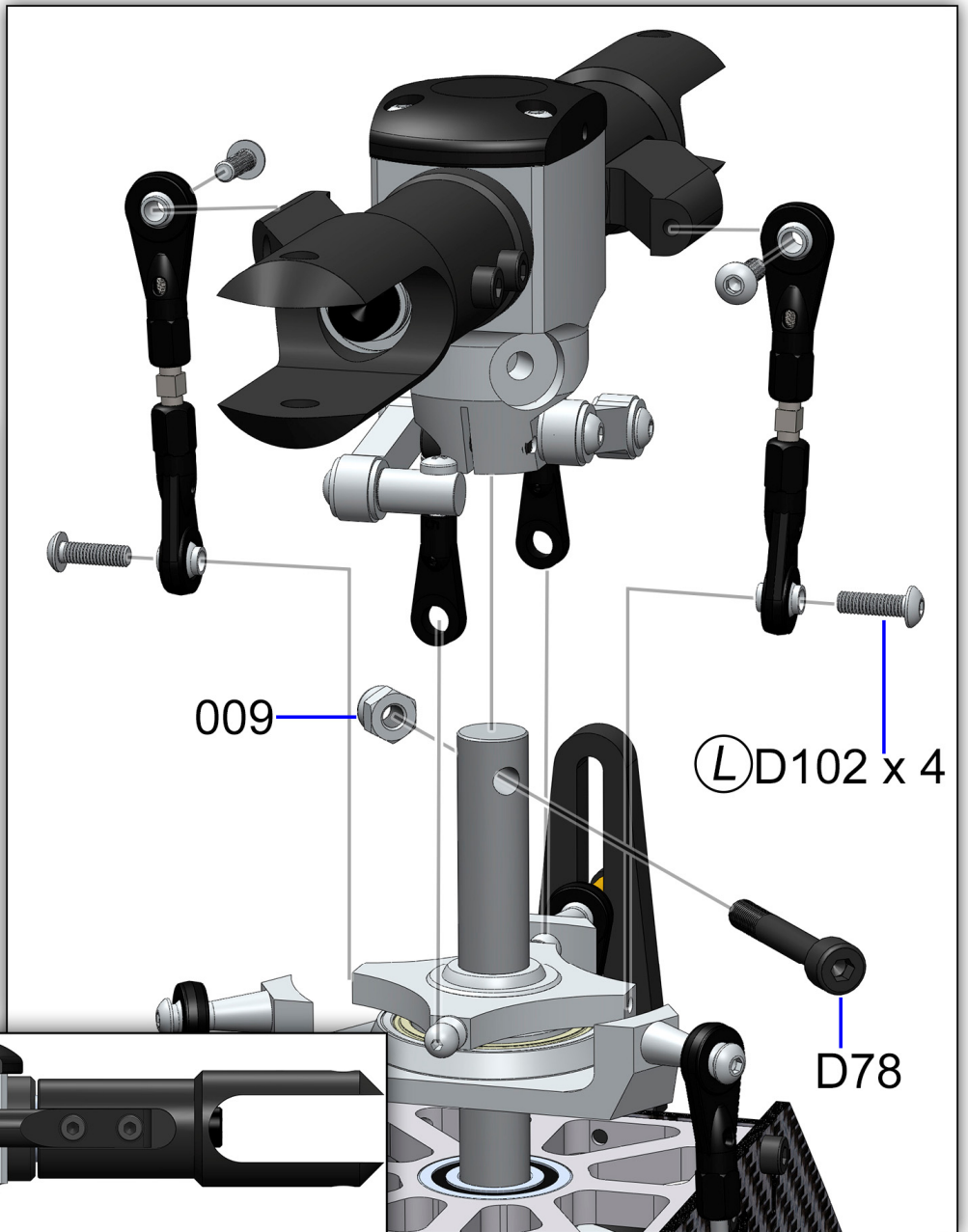
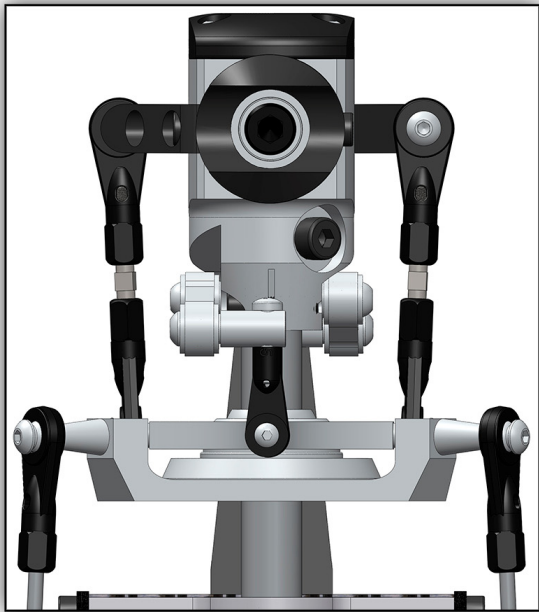

(L) = Loctite 243

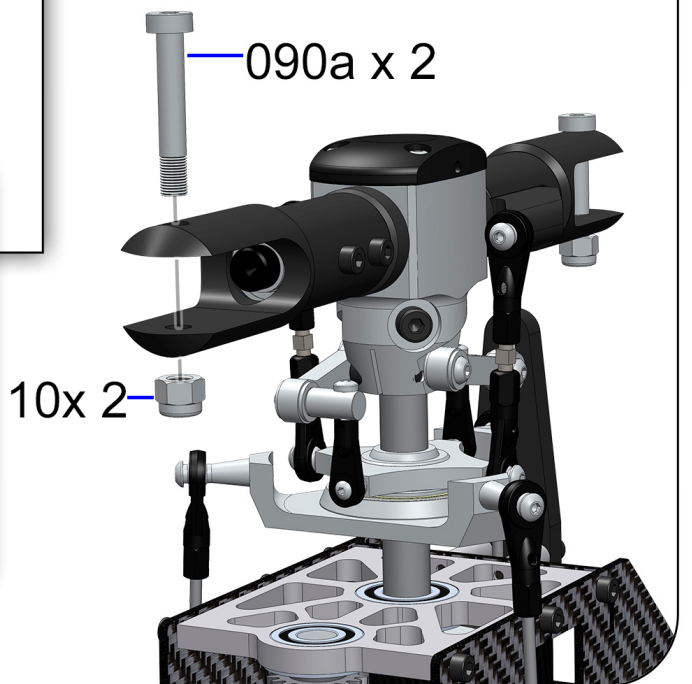



30

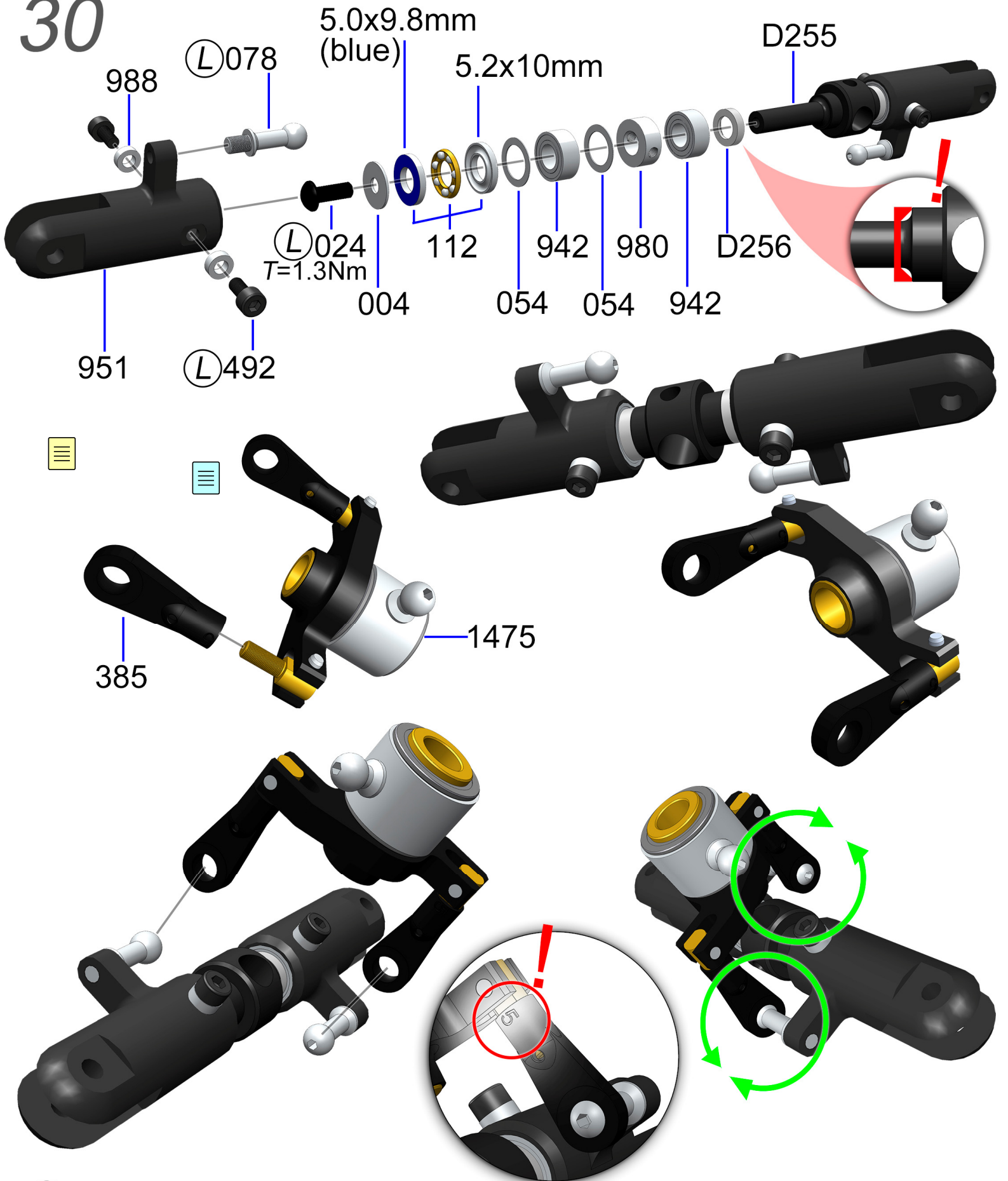

(L) = Loctite 243

*minicopter*

*Diabolo L*

31

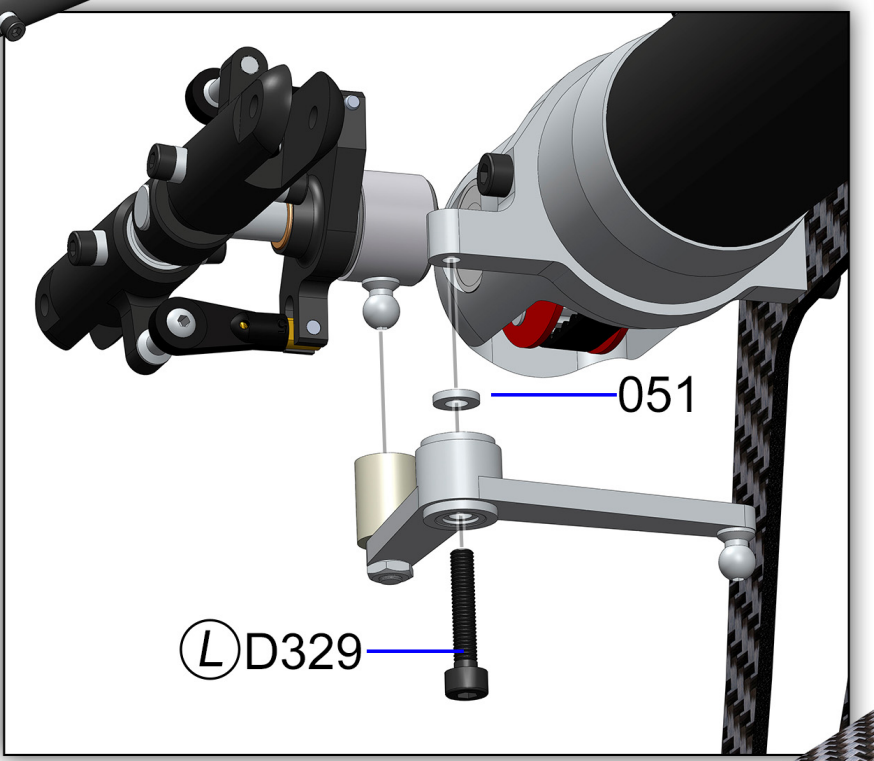
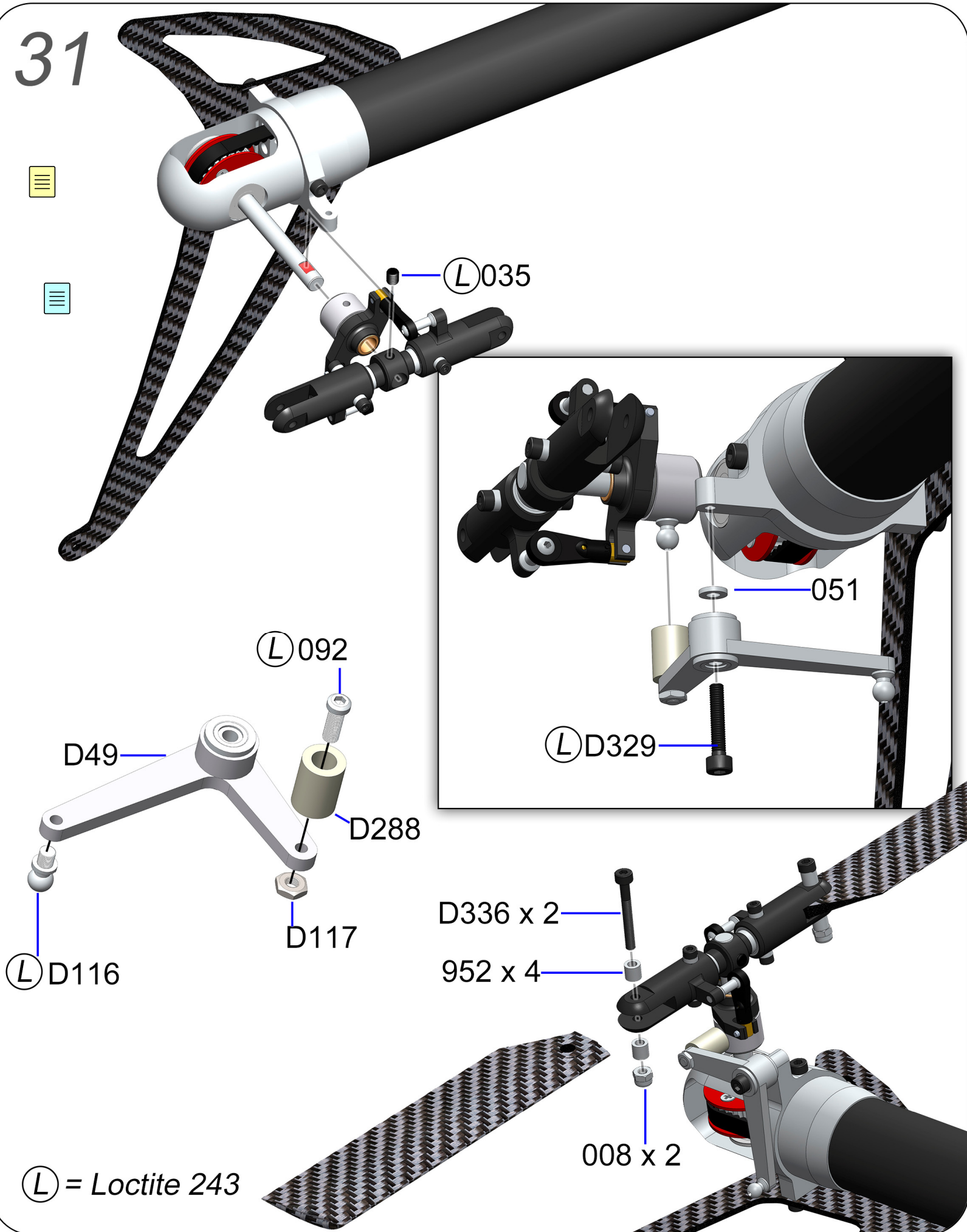

(L) = Loctite 243

*minicopter*

*Diabolo L*



32

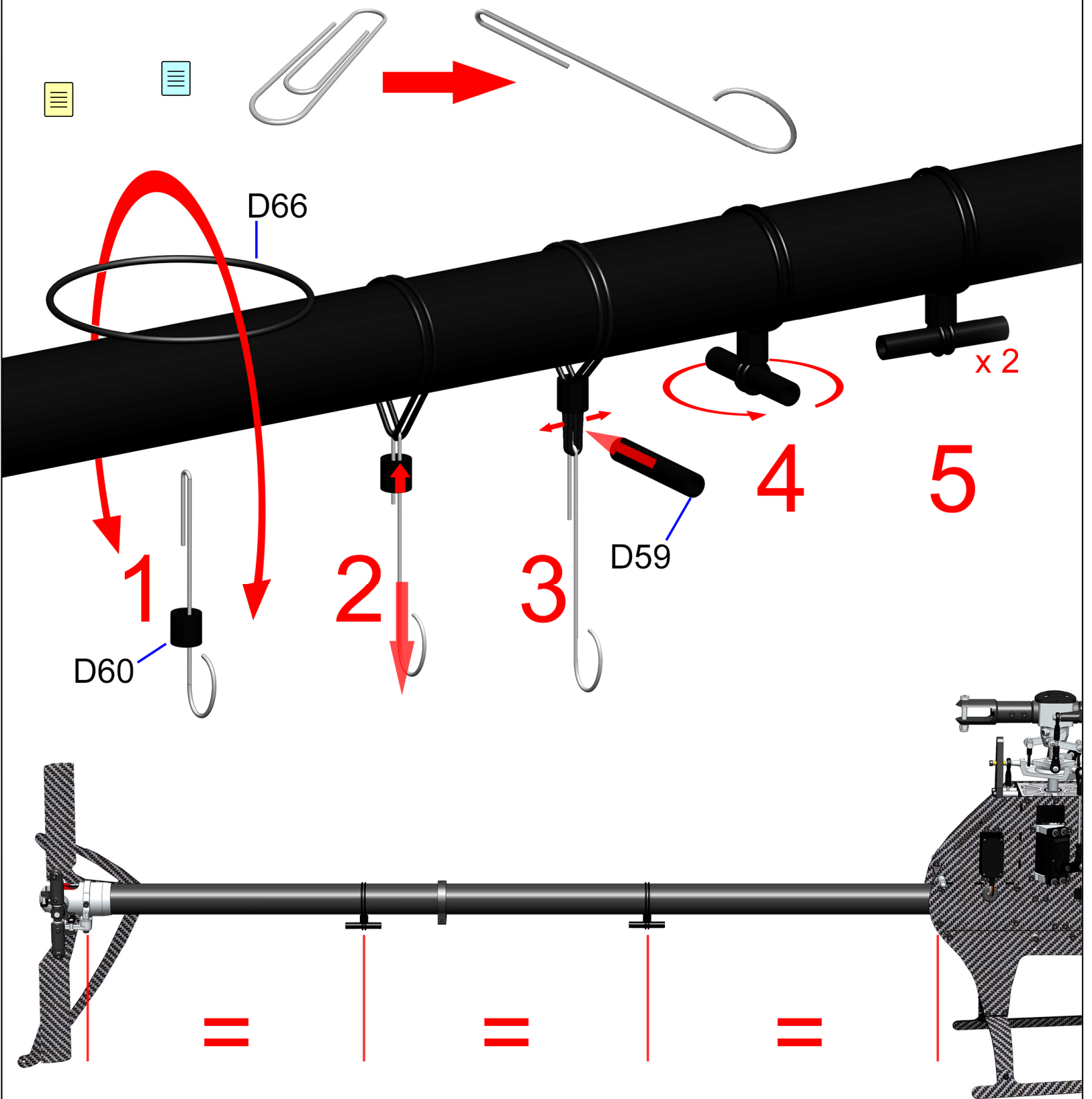

*minicopter*

*Diabolo L*

33

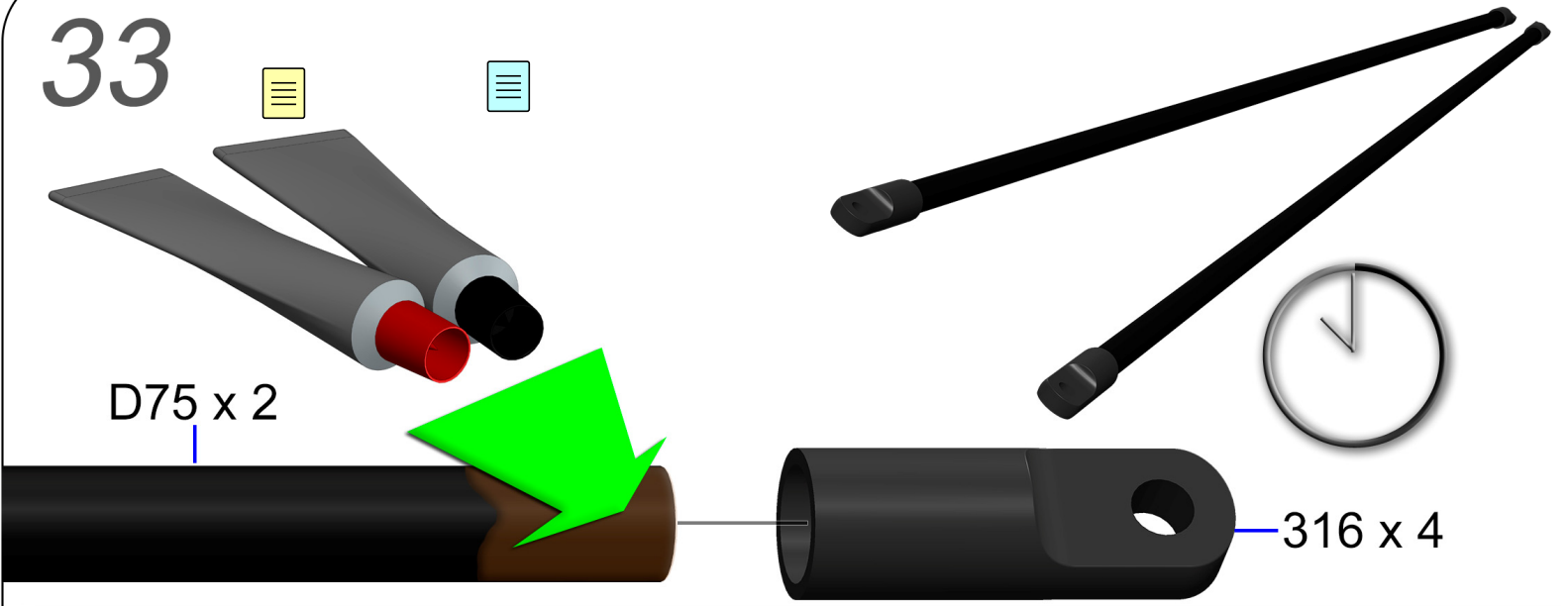

D75 x 2

316 x 4

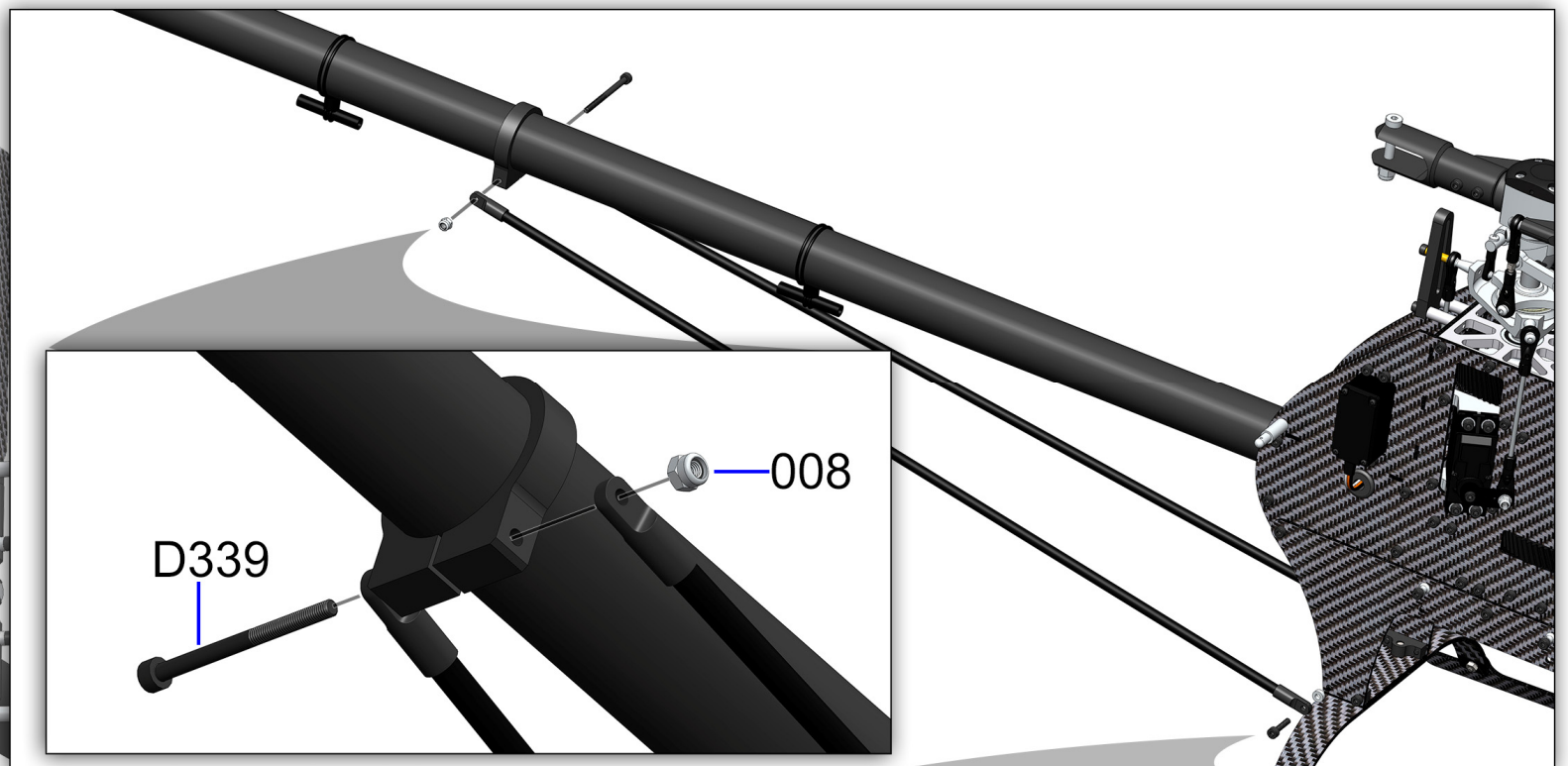

008

D339



(L) = Loctite 243

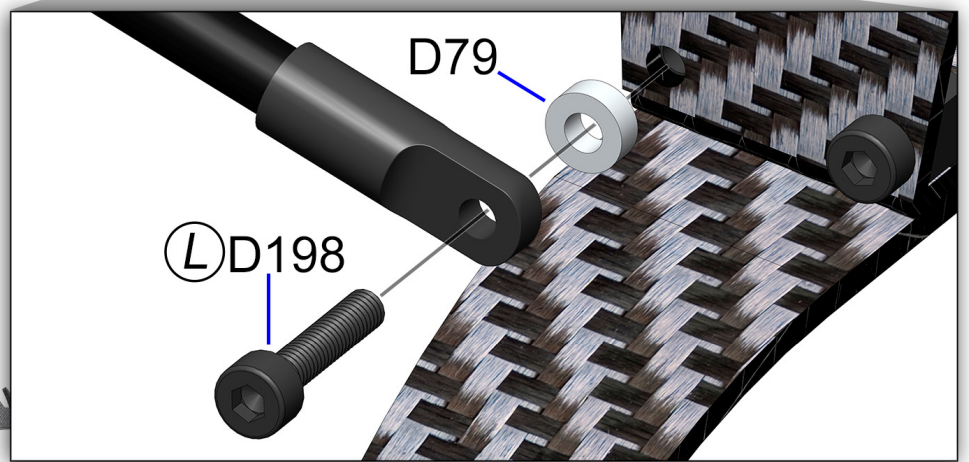

D79

(L) D198

*minicopter*

*Diabolo L*



34

17-18.5mm

ø 1.8mm  
(5/64")



001 x 2

007



D118

099

087 x 2



041 x 2

350

8mm

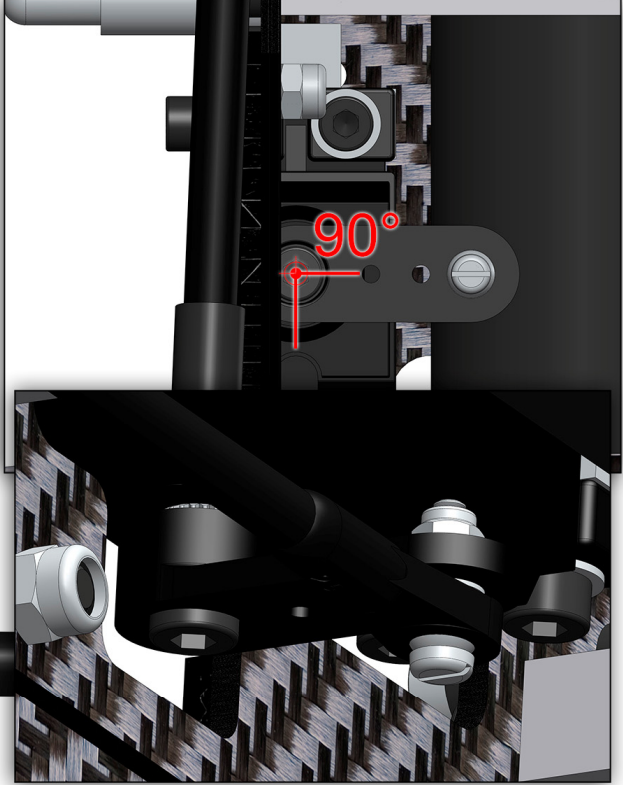
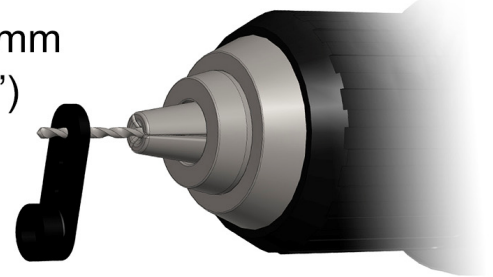

8mm

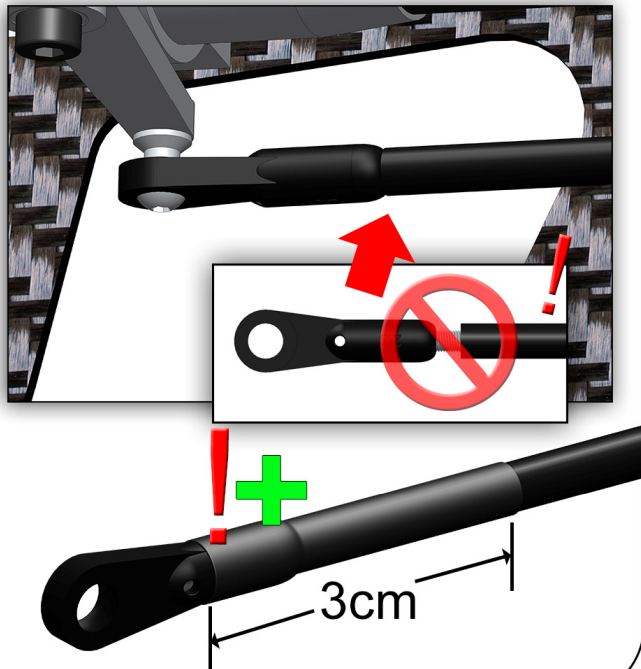
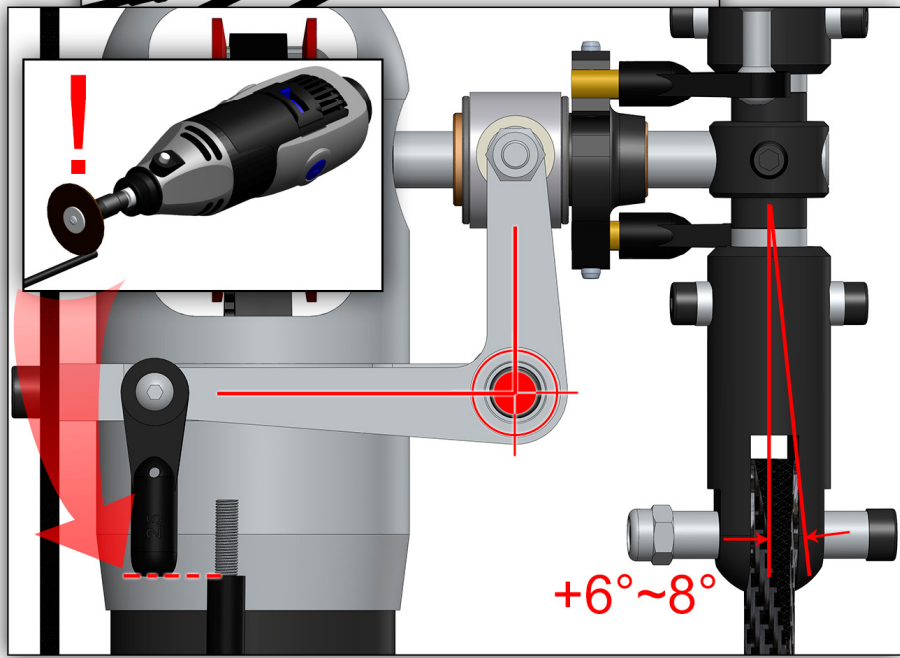

*minicopter*

*Diabolo L*

35

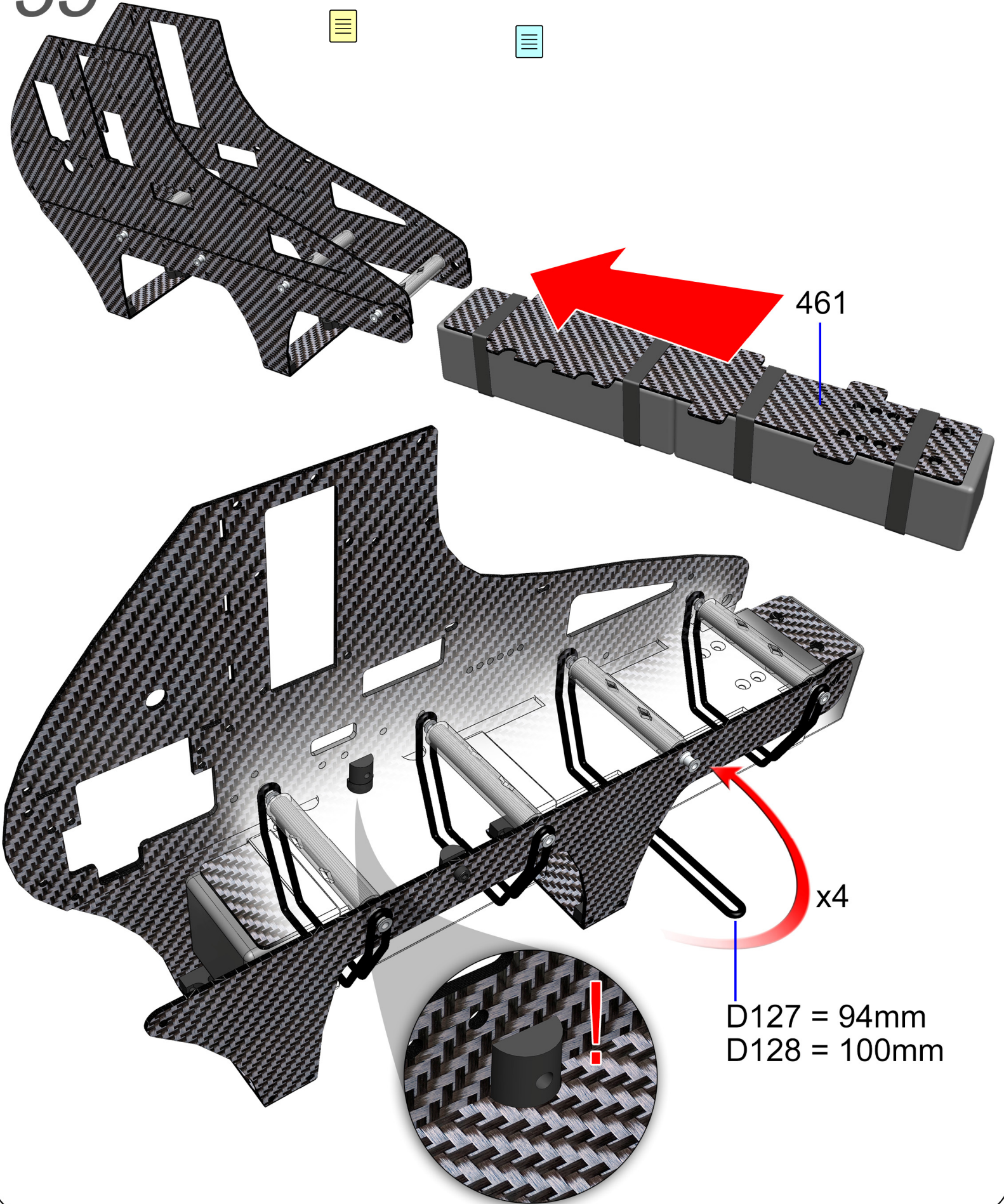

461

x4

D127 = 94mm  
D128 = 100mm

*minicopter*

*Diabolo L*



36



2.5 x 200

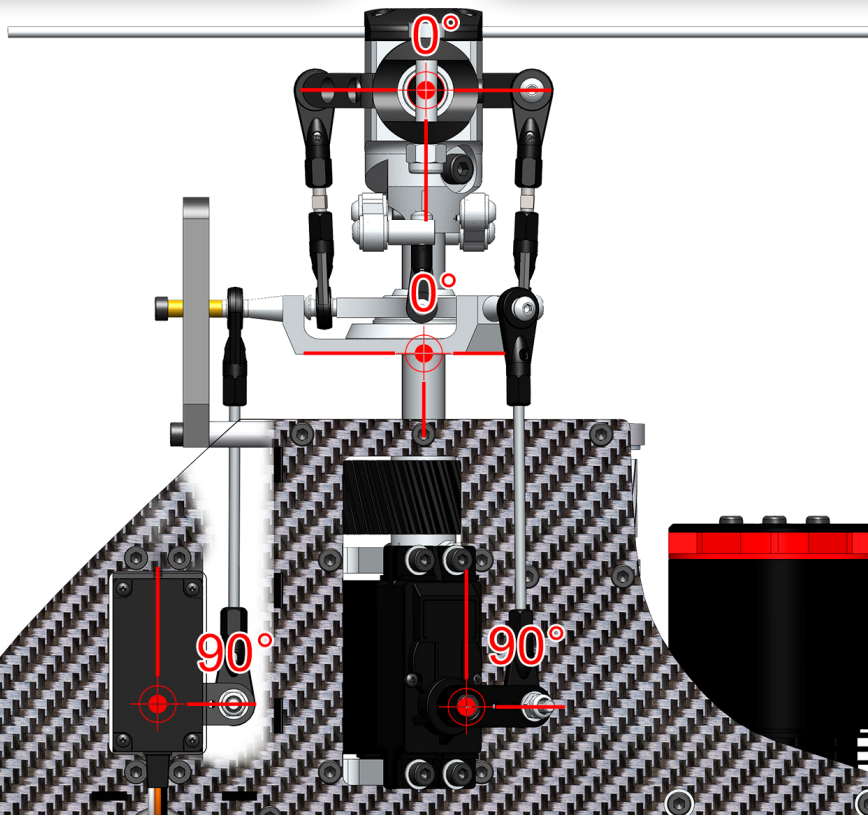
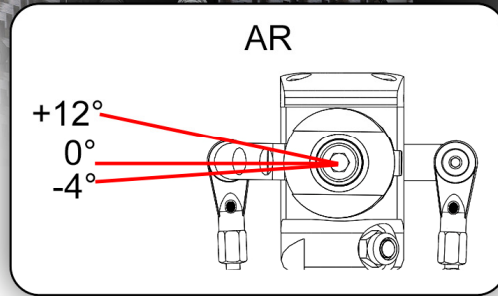
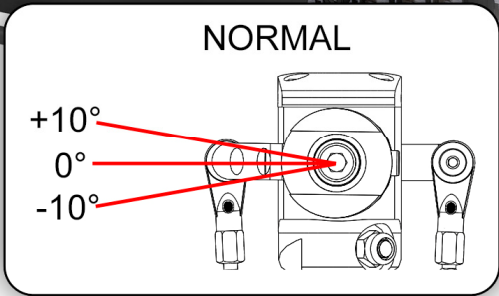
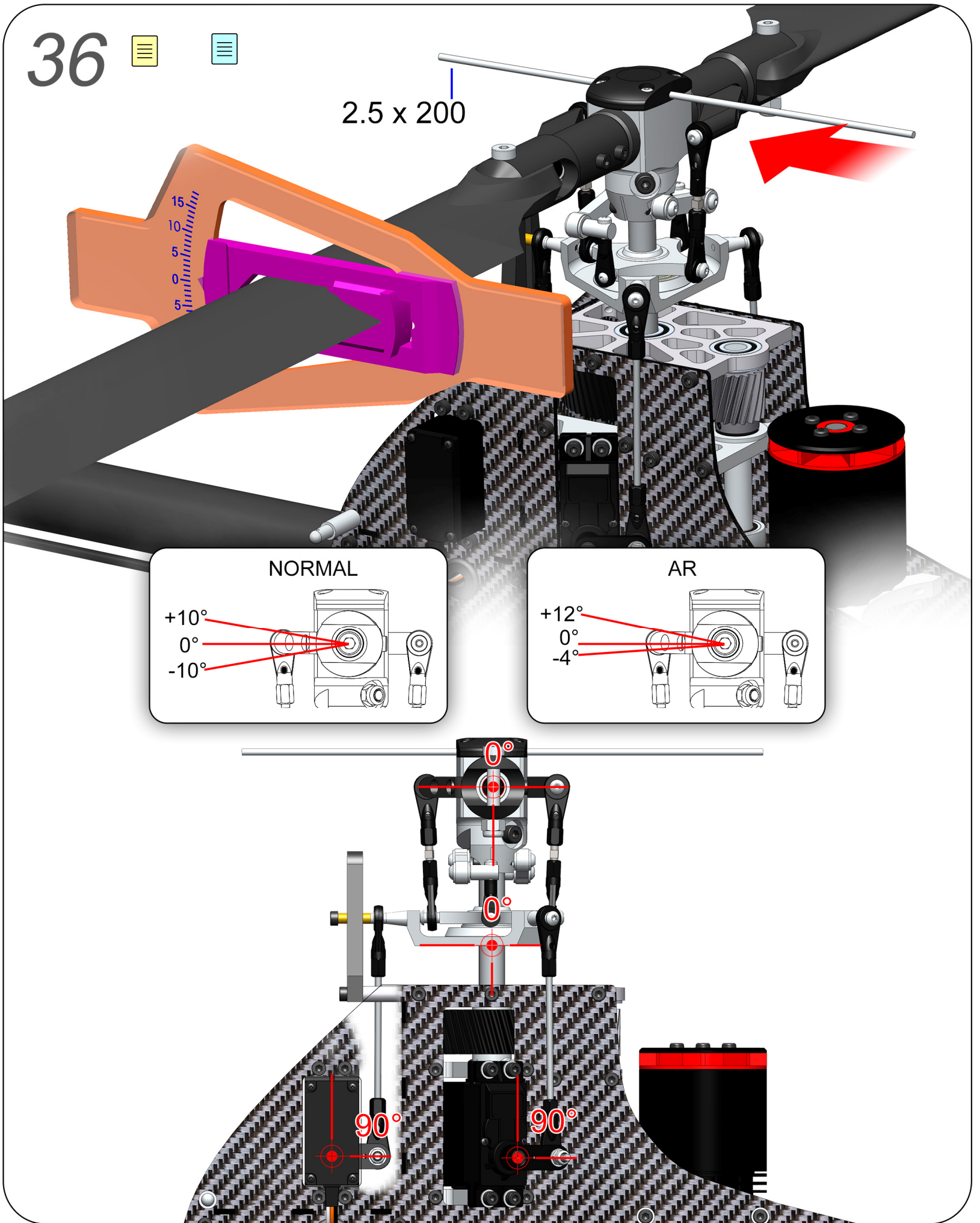

*minicopter*

*Diabolo L*